

MCGILL[®] Inch Cam Follower Bearings

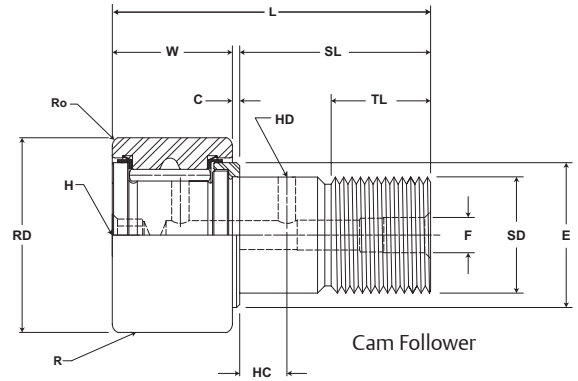

- Basic Construction Type:** Stud Type Crowned / Cylindrical Outside Diameter
- Rolling Elements:** Full Complement Needle Roller
- Bearing Material:** Bearing Quality Steel
- Seal Type:** LUBRI-DISC[®]
- Lubrication:** Lithium Soap Grease NLGI #2
- System Configuration:** Concentric / Eccentric / Heavy Stud
- Mounting Feature:** Slot / Hex Hole



CF, CFE, CFH

Part No.		RD		W		SD		SL	C	TL	L	R	ECC	G	BD	Track Roller Dynamic Rating	Track Roller Static Rating
W/O Seals	With LUBRI-DISC Seals	Roller Diameter		Roller Width		Stud Diameter		Stud Length	Endplate Extension	Min Thread Length	Length Overall	Crown Prefix CCF-XX	Eccentric Base Modifier CFE-XX				
		inch mm		inch mm		inch mm		inch mm	inch mm	inch mm	inch mm	inch mm	inch mm				
		Nom.	Tol.	Nom.	Tol.	Nom.	Tol.	(Ref)	(Ref)	(Ref)	(Ref)	Radius (Ref)	(Ref)	+0/-0.010	±.001	lb/N	
-	CF 5 SB	5.000	+0/-0.001	2.750	+0 / -0.005	2.000	+0.01/-0	5.06	.062	2.563	7.88	Cylindrical	N/A	N/A	N/A	46,575	67,950
	CCF 5 SB	127.00	+0/-0.03	69.85	+0 / -0.13	50.80	+0.03/-0	128.6	1.57	65.1	200.0	48 1,219					
	CFH 5 SB	5.000	+0/-0.001	2.750	+0 / -0.005	2.500	+0.01/-0	5.06	.062	2.563	7.88	Cylindrical	N/A	N/A	N/A	46,575	135,900
	CCFH 5 SB	127.00	+0/-0.03	69.85	+0 / -0.13	63.50	+0.03/-0	128.6	1.57	65.1	200.0	48 1,219					
-	CF 6 SB	6.000	+0/-0.001	3.250	+0 / -0.005	2.500	+0.01/-0	6.00	.062	3.00	9.31	Cylindrical	N/A	N/A	N/A	60,000	80,450
	CCF 6 SB	152.40	+0/-0.03	82.55	+0 / -0.13	63.50	+0.03/-0	152.4	1.57	76.2	236.5	56 1,422					
	CFH 6 SB	6.000	+0/-0.001	3.250	+0 / -0.005	2.500	+0.01/-0	6.00	.062	3.00	9.31	Cylindrical	N/A	N/A	N/A	60,000	160,900
	CCFH 6 SB	152.40	+0/-0.03	82.55	+0 / -0.13	63.50	+0.03/-0	152.4	1.57	76.2	236.5	56 1,422					
-	CF 7 SB	7.000	+0/-0.001	3.750	+0 / -0.005	3.000	+0.01/-0	7.69	.062	4.125	11.50	Cylindrical	N/A	N/A	N/A	75,380	106,930
	CCF 7 SB	177.80	+0/-0.03	95.25	+0 / -0.13	76.20	+0.03/-0	195.3	1.57	104.77	292.1	60 1,524					
	CFH 7 SB	7.000	+0/-0.001	3.750	+0 / -0.005	3.000	+0.01/-0	7.69	.062	4.125	11.50	Cylindrical	N/A	N/A	N/A	75,380	213,860
	CCFH 7 SB	177.80	+0/-0.03	95.25	+0 / -0.13	76.20	+0.03/-0	195.3	1.57	104.77	292.1	60 1,524					
-	CF 8 SB	8.000	*	4.250	*	3.250	+0.01/-0	8.50	.125	4.25	12.81	Cylindrical	N/A	N/A	N/A	92,200	144,100
	CCF 8 SB	203.20		107.95		82.55	+0.03/-0	215.9	3.175	107.95	325.4	40 1,016					
-	CF 9 SB	9.000	*	4.750	*	3.750	+0.01/-0	9.50	.125	4.75	14.31	Cylindrical	N/A	N/A	N/A	113,260	183,430
	CCF 9 SB	228.60		120.65		95.25	+0.03/-0	241.3	3.175	120.65	363.5	40 1,016					
-	CF 10 SB	10.000	*	5.250	*	4.250	+0.01/-0	10.00	.125	4.75	15.31	Cylindrical	N/A	N/A	N/A	131,545	215,565
	CCF 10 SB	254.00		133.35		107.95	+0.03/-0	254.0	3.175	120.65	388.9	40 1,016					

Metric dimensions for reference only.
 *Standard tolerances do not apply. Consult Application Engineering.
 Hex wrench size for "Broached" version is located in the wrench size chart on page B-156.

Not all parts are available from stock. Please contact customer service for availability (800) 626-2120.
 For more information on bearing capabilities outside of our standard offering, please contact Application Engineering (800) 626-2093.

Inch Cam Follower Bearings **McGILL**

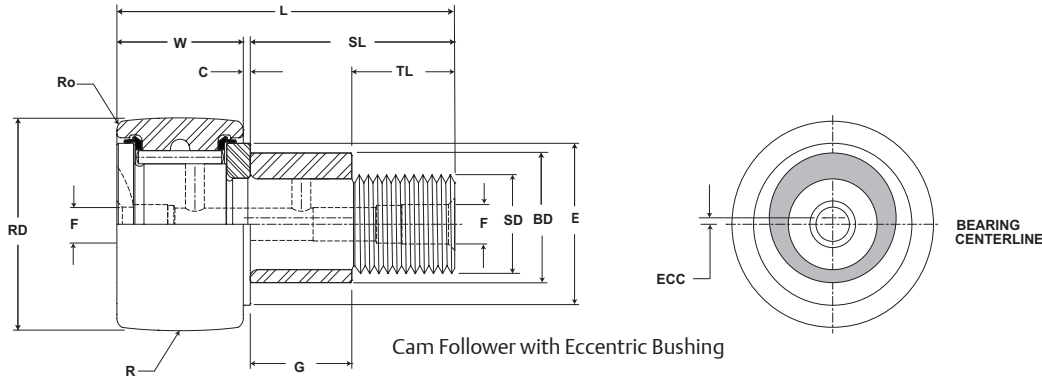

CF, CFE, CFH

Part No.		HC	HD	F	E	Ro	HBD		Thread Type	Clamping Torque	Limiting Speed (Grease)	WT
W/O Seals	With LUBRI-DISC Seals	Hole Center	Radial Hole Diameter	Axial Hole Dia or Fitting	Min Boss Diameter	Outer Corner	Housing Bore Diameter					
		inch mm		inch mm		inch mm						
		(Ref)	(Ref)	(Ref)	(Ref)	Nom.	Tol.	in-lb Nm				
-	CF 5 S	.875	.1875	1/4" NPT	3.563	.125	2.0003	+0.002/-0.003	2-12	5,000	575	19.60
	CCF 5 S	22	5		90.49	3.18	50.808	+0.005/-0.008				
	CFH 5 S	.875	.1875	1/4" NPT	3.563	.125	2.5030	+0.002/-0.003	2 1/2-12	5,000	575	22.10
	CCFH 5 S	22	5		90.49	3.18	63.576	+0.005/-0.008				
-	CF 6 S	1.00	.1875	1/4" NPT	4.469	.125	2.5030	+0.002/-0.003	2 1/2-12	5,000	475	32.73
	CCF 6 S	25	5		113.51	3.18	63.576	+0.005/-0.008				
	CFH 6 S	1.00	.1875	1/4" NPT	4.469	.125	3.0003	+0.002/-0.003	3-12	5,000	475	36.41
	CCFH 6 S	25	5		113.51	3.18	76.208	+0.005/-0.008				
-	CF 7 S	1.25	.1875	1/4" NPT	5.188	.125	3.0003	+0.002/-0.003	3-12	5,000	400	54.73
	CCF 7 S	32	5		131.76	3.18	76.208	+0.005/-0.008				
	CFH 7 S	1.25	.1875	1/4" NPT	5.188	.125	3.5003	+0.002/-0.003	3 1/2-4	5,000	400	68.03
	CCFH 7 S	32	5		131.76	3.18	88.908	+0.005/-0.008				
-	CF 8 S	-	-	1/4" NPT	4.375	.219	3.2503	+0.002/-0.003	3 1/4-4	5,000	350	79.80
	CCF 8 S	-	-		111.13	5.56	82.558	+0.005/-0.008				
-	CF 9 S	-	-	1/4" NPT	5.063	.250	3.7503	+0.002/-0.003	3 1/2-4	5,000	300	111.60
	CCF 9 S	-	-		128.59	6.35	95.258	+0.005/-0.008				
-	CF 10 S	-	-	1/4" NPT	5.469	.281	4.2503	+0.002/-0.003	3 1/2-4	5,000	275	148.20
	CCF 10 S	-	-		138.91	7.14	107.958	+0.005/-0.008				

For positive clamping, use housing thickness equal to G dimension = .010".
Clamping torque based on dry threads. For wet (lubricated) threads, use half of value shown.
Hex wrench size for "Broached" version is located in the wrench size chart on page B-156.