

SSPM TYPE

— Keyless Spline Nut —

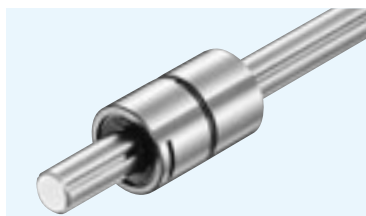

part number structure

example **SSPM 10-2-T1-200-P/CU**

SSPM type

nominal diameter

number of nuts attached to one shaft

Note: retainer material is resin.

spline shaft total length

with special specification

accuracy grade
blank: high
P: precision

preload symbol
blank: standard
T1: light

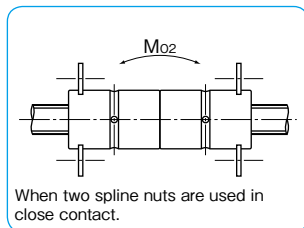

When two spline nuts are used in close contact.

part number	major dimensions											
	D mm	tolerance μm	L mm	tolerance mm	F mm	W mm	C mm	A mm	d mm	B mm	H mm	K mm
SSPM 6	14	0	25	0	2.2	1.1	1.0	12.0	1	9.4	25.6	6.8
SSPM 8	16	-11	25	-0.2	2.7	1.3	1.2	13.6	1.5	11	30.6	8.5
SSPM10	21	0/-13	33	-0.2	2.7	1.3	1.2	18.6	1.5	13.5	35.6	8.5

Two F type lock plates per SSPM type spline nut are provided (refer to page B-15).

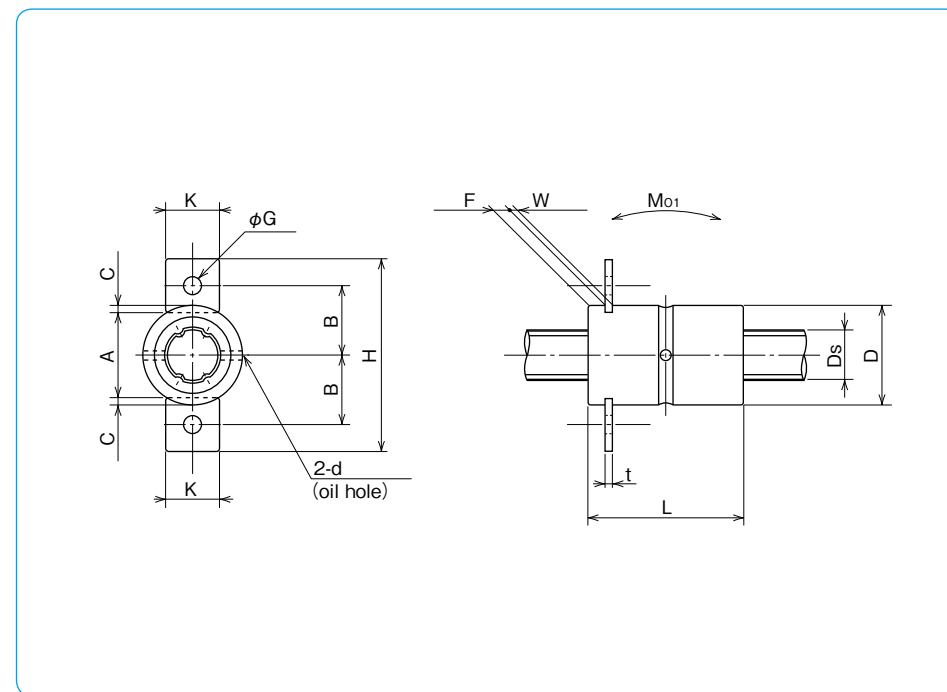

G mm	t mm	Ds mm	tolerance μm	basic torque rating		basic load rating		allowable static moment		mass		
				dynamic C _T N·m	static Co _T N·m	dynamic C kN	static Co kN	Mo ₁ N·m	Mo ₂ N·m	nut kg	shaft kg/m	size
2.9	1.0	6	0/-12	1.5	2.4	1.22	2.28	5.1	40	0.019	0.21	6
3.5	1.2	8	0	2.1	3.7	1.45	2.87	7.4	50	0.023	0.38	8
3.5	1.2	10	-15	4.4	8.2	2.73	5.07	18.0	116	0.054	0.60	10

1kN≒102kgf 1N·m≒0.102kgf·m

SSPF TYPE

— Flange Type Nut —



part number structure

example **SSPF 25 - 2 - T1 - 436 - P / CU**

specification
SSPF: standard
SSPFS: anti-corrosion

nominal diameter

number of nuts attached to one shaft

Note: retainer material is resin.

with special specification

accuracy grade
blank: high
P: precision

spline shaft total length

preload symbol
blank: standard
T1: light
T2: medium

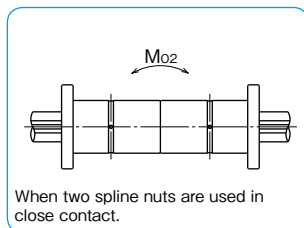

When two spline nuts are used in close contact.

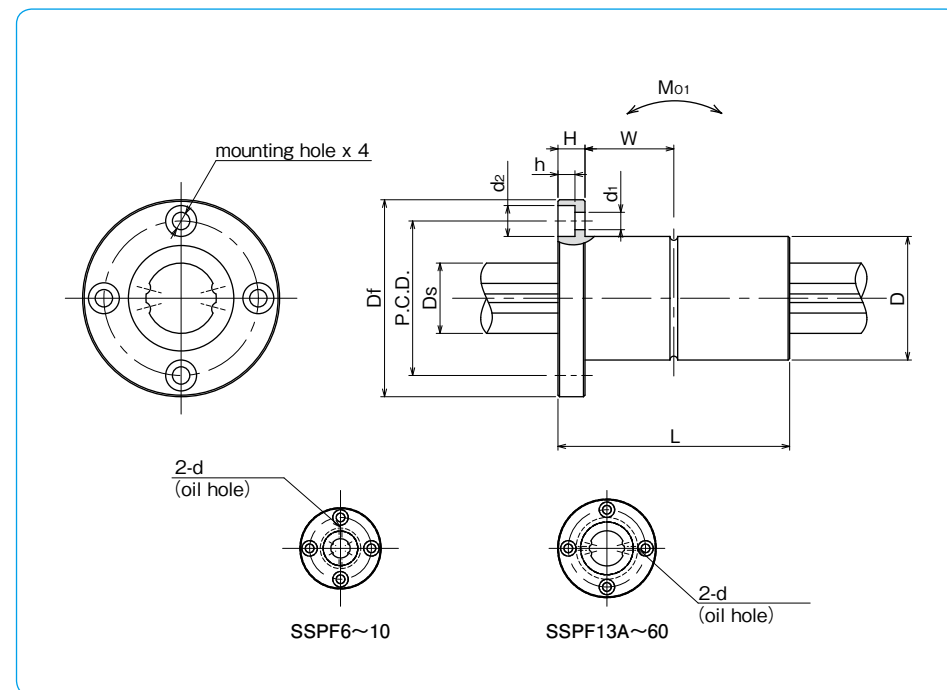

part number		D		L		major dimensions				
standard	anti-corrosion	mm	tolerance μm	mm	tolerance mm	Df mm	H mm	P.C.D. mm	$d_1 \times d_2 \times h$ mm	W mm
SSPF 6	SSPFS 6	14	0	25	0	30	5	22	3.4×6.5×3.3	7.5
SSPF 8	SSPFS 8	16	-11	25		32	5	24	3.4×6.5×3.3	7.5
SSPF10	SSPFS10	21	0	33		42	6	32	4.5×8×4.4	10.5
SSPF13A	SSPFS13A	24	-13	36	-0.2	43	7	33	4.5×8×4.4	11
SSPF16A	SSPFS16A	31		50	0	50	7	40	4.5×8×4.4	18
SSPF20A	SSPFS20A	35	0	63		58	9	45	5.5×9.5×5.4	22.5
SSPF25A	SSPFS25A	42	-16	71		65	9	52	5.5×9.5×5.4	26.5
SSPF30A	—	47		80	0	75	10	60	6.6×11×6.5	30
SSPF40A	—	64	0	100		100	14	82	9×14×8.6	36
SSPF50A	—	80	-19	125		124	16	102	11×17.5×11	46.5
SSPF60A	—	90	0/-22	140	-0.3	129	18	107	11×17.5×11	52
SSPF20	SSPFS20	32		60	0/-0.2	51	7	40	4.5×8×4.4	23
SSPF25	SSPFS25	37	0	70	0	60	9	47	5.5×9.5×5.4	26
SSPF30	—	45	-16	80		70	10	54	6.6×11×6.5	30
SSPF40	—	60	0	100		90	14	72	9×14×8.6	36
SSPF50	—	75	-19	112	-0.3	113	16	91	11×17.5×11	40
SSPF60	—	90	0/-22	127		129	18	107	11×17.5×11	45.5

d	Ds	tolerance μm	basic torque rating		basic load rating		allowable static moment		mass		size
			dynamic C_T N·m	static C_{0T} N·m	dynamic C kN	static C_0 kN	M_{O1} N·m	M_{O2} N·m	nut kg	shaft kg/m	
1	6	0/-12	1.5	2.4	1.22	2.28	5.1	40	0.037	0.21	6
1.5	8	0	2.1	3.7	1.45	2.87	7.4	50	0.042	0.38	8
1.5	10	-15	4.4	8.2	2.73	5.07	18.0	116	0.094	0.6	10
1.5	13	0	21	39.2	2.67	4.89	13.7	109	0.1	1	13A
2	16	-18	60	110	6.12	11.2	46	299	0.2	1.5	16A
2	20		105	194	8.9	16.3	110	560	0.33	2.4	20A
3	25	0	189	346	12.8	23.4	171	1,020	0.45	3.7	25A
3	30	-21	307	439	18.6	23.2	181	1,470	0.55	5.38	30A
4	40	0	674	934	30.8	37.5	358	2,940	1.41	9.55	40A
4	50	-25	1,290	2,950	40.3	64.9	690	4,080	2.73	15.0	50A
4	60	0/-30	1,570	2,620	47.7	79.5	881	5,470	3.2	21.6	60A
2	18.2		83	133	7.84	11.3	63	500	0.22	2	20
3	23	0	162	239	12.3	16.1	104	830	0.32	3.1	25
3	28	-21	289	412	18.6	23.2	181	1,470	0.51	4.8	30
4	37.4	0	637	882	30.8	37.5	358	2,940	1.15	8.6	40
4	47	-25	1,390	3,180	46.1	74.2	696	4,400	2.1	13.1	50
4	56.5	0/-30	2,100	4,800	58.0	127	1,300	8,800	3.3	19	60

1kN=102kgf 1N·m=0.102kgf·m