

## 7.9 LGBXS...B

### Linear guide without ball chain, carriages in block design, flat design height

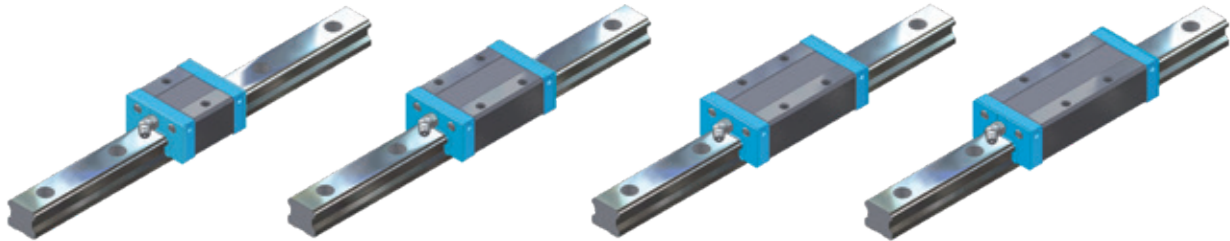

LGBXS...BS, short

LGBXS...BN, standard

LGBXS...BL, long

LGBXS...BE, extra long

#### Example of order code

LGBXS 25 BN 2 SS L 02000 N Z1 - 2 - 0 -20.0 N\*

\*Explanation to type code in Chapter 8

	System mm					Carriage mm											
	H	W	W2	E	L	B	J	MQ	I	L1	H2	T1	N	T2	L2	H3	Lx
LGBXS15 BS	24	34	9,5	3,4	40,6	26	--	M 4	4,8	22,2	M 3 x 0,5	5,5	5,7	4,5	4,20	M 3 x 0,5	3,0
LGBXS15 BN	24	34	9,5	3,4	58,6	26	26	M 4	4,8	40,2	M 3 x 0,5	5,5	5,7	4,5	4,20	M 3 x 0,5	3,0
LGBXS15 BL	24	34	9,5	3,4	66,1	26	26	M 4	4,8	47,7	M 3 x 0,5	5,5	5,7	4,5	4,20	M 3 x 0,5	3,0
LGBXS20 BS	28	42	11,0	4,5	49,1	32	--	M 5	5,5	27,5	M 6 x 1,0	5,1	12,3	4,3	4,25	M 6 x 1,0	3,8
LGBXS20 BN	28	42	11,0	4,5	70,1	32	32	M 5	5,5	48,5	M 6 x 1,0	7,1	12,3	4,3	4,25	M 6 x 1,0	3,8
LGBXS25 BS	33	48	12,5	5,8	54,0	35	--	M 6	6,8	32,3	M 6 x 1,0	7,2	12,2	6,4	4,65	M 6 x 1,0	5,0
LGBXS25 BN	33	48	12,5	5,8	79,2	35	35	M 6	6,8	57,5	M 6 x 1,0	7,2	12,2	6,4	4,65	M 6 x 1,0	5,0
LGBXS30 BS	42	60	16,0	7,0	64,2	40	--	M 8	10,0	37,2	M 6 x 1,0	10,0	11,7	5,5	6,00	M 6 x 1,0	5,0
LGBXS30 BN	42	60	16,0	7,0	94,8	40	40	M 8	10,0	67,8	M 6 x 1,0	10,0	11,7	5,5	6,00	M 6 x 1,0	5,0
LGBXS30 BL	42	60	16,0	7,0	105,0	40	40	M 8	10,0	78,0	M 6 x 1,0	10,0	11,7	5,5	6,00	M 6 x 1,0	5,0
LGBXS30 BE	42	60	16,0	7,0	130,5	40	60	M 8	10,0	103,5	M 6 x 1,0	10,0	11,7	5,5	6,00	M 6 x 1,0	5,0
LGBXS35 BS	48	70	18,0	7,5	75,5	50	--	M 8	10,0	44,5	M 6 x 1,0	11,5	11,5	10,5	7,25	M 6 x 1,0	5,0
LGBXS35 BN	48	70	18,0	7,5	111,5	50	50	M 8	10,0	80,5	M 6 x 1,0	11,5	11,5	10,5	7,25	M 6 x 1,0	5,0
LGBXS35 BL	48	70	18,0	7,5	123,5	50	50	M 8	10,0	92,5	M 6 x 1,0	11,5	11,5	10,5	7,25	M 6 x 1,0	5,0
LGBXS35 BE	48	70	18,0	7,5	153,5	50	72	M 8	10,0	122,5	M 6 x 1,0	11,5	11,5	10,5	7,25	M 6 x 1,0	5,0
LGBXS45 BN	60	86	20,5	8,9	129,0	60	60	M 10	15,5	94,0	M 8 x 1,25	14,4	10,8	14,5	8,00	M 8 x 1,25	7,5
LGBXS45 BL	60	86	20,5	8,9	145,0	60	60	M 10	15,5	110,0	M 8 x 1,25	14,4	10,8	14,5	8,00	M 8 x 1,25	7,5
LGBXS45 BE	60	86	20,5	8,9	174,0	60	80	M 10	15,5	139,0	M 8 x 1,25	14,4	10,8	14,5	8,00	M 8 x 1,25	7,5
LGBXS55 BN	70	100	23,5	12,7	155,0	75	75	M 12	18,0	116,0	M 8 x 1,25	14,0	10,8	14,5	10,00	M 8 x 1,25	7,5
LGBXS55 BL	70	100	23,5	12,7	193,0	75	75	M 12	18,0	154,0	M 8 x 1,25	14,0	10,8	14,5	10,00	M 8 x 1,25	7,5
LGBXS55 BE	70	100	23,5	12,7	210,0	75	95	M 12	18,0	171,0	M 8 x 1,25	14,0	10,8	14,5	10,00	M 8 x 1,25	7,5

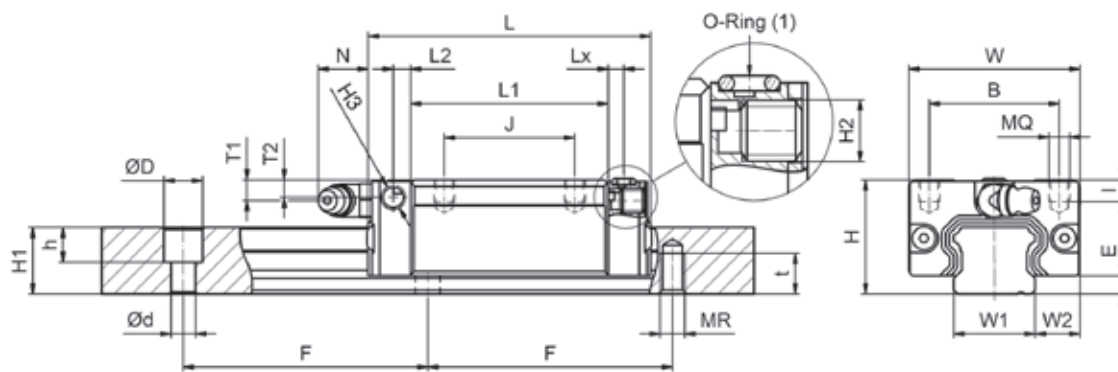
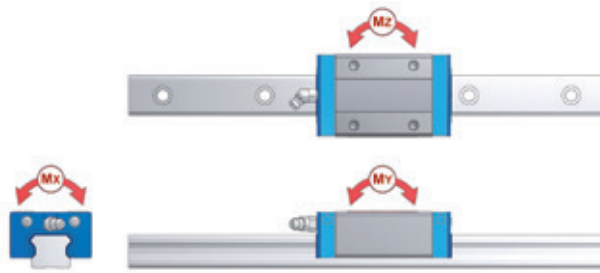

Rail [mm]									Load rating					Mass			
W1	H1	F	Version L			Version C		kN		kNm			kg	kg/ m			
			d	D	h	MR	t	C	C0	MX	MY	MZ	Chariot	Rail			
15	13,0	60	4,5	7,5	5,5	M 5	8,0	4,70	9,90	0,069	0,032	0,032	0,10	1,28	LGBXS15	BS	
15	13,0	60	4,5	7,5	5,5	M 5	8,0	9,46	19,90	0,137	0,120	0,120	0,17	1,28	LGBXS15	BN	
15	13,0	60	4,5	7,5	5,5	M 5	8,0	11,39	24,05	0,166	0,171	0,171	0,18	1,28	LGBXS15	BL	
20	16,3	60	6,0	9,5	8,5	M 6	10,0	7,49	15,93	0,148	0,066	0,066	0,17	2,15	LGBXS20	BS	
20	16,3	60	6,0	9,5	8,5	M 6	10,0	14,57	30,96	0,289	0,224	0,224	0,22	2,15	LGBXS20	BN	
23	19,2	60	7,0	11,0	9,0	M 6	12,0	10,45	21,34	0,230	0,103	0,103	0,21	2,88	LGBXS25	BS	
23	19,2	60	7,0	11,0	9,0	M 6	12,0	20,44	41,73	0,447	0,358	0,358	0,38	2,88	LGBXS25	BN	
28	22,8	80	9,0	14,0	12,0	M 8	15,0	14,99	27,51	0,356	0,153	0,153	0,50	4,45	LGBXS30	BS	
28	22,8	80	9,0	14,0	12,0	M 8	15,0	30,24	55,50	0,719	0,560	0,560	0,80	4,45	LGBXS30	BN	
28	22,8	80	9,0	14,0	12,0	M 8	15,0	39,16	71,88	0,931	0,836	0,836	0,94	4,45	LGBXS30	BL	
28	22,8	80	9,0	14,0	12,0	M 8	15,0	43,60	88,18	1,142	1,361	1,361	1,16	4,45	LGBXS30	BE	
34	26,0	80	9,0	14,0	12,0	M 8	17,0	21,64	41,43	0,655	0,275	0,275	0,80	6,25	LGBXS35	BS	
34	26,0	80	9,0	14,0	12,0	M 8	17,0	44,19	82,66	1,307	0,991	0,991	1,20	6,25	LGBXS35	BN	
34	26,0	80	9,0	14,0	12,0	M 8	17,0	53,96	103,29	1,633	1,424	1,424	1,40	6,25	LGBXS35	BL	
34	26,0	80	9,0	14,0	12,0	M 8	17,0	59,37	127,68	2,020	2,330	2,330	1,84	6,25	LGBXS35	BE	
45	31,1	105	14,0	20,0	17,0	M 12	20,0	59,25	111,30	2,353	1,559	1,559	1,64	9,60	LGBXS45	BN	
45	31,1	105	14,0	20,0	17,0	M 12	20,0	70,47	132,39	2,798	2,170	2,170	1,93	9,60	LGBXS45	BL	
45	31,1	105	14,0	20,0	17,0	M 12	20,0	81,42	166,87	3,527	3,455	3,455	2,42	9,60	LGBXS45	BE	
53	38,0	120	16,0	23,0	20,0	M 14	24,0	71,49	136,62	3,385	2,361	2,361	2,67	13,80	LGBXS55	BN	
53	38,0	120	16,0	23,0	20,0	M 14	24,0	96,46	183,14	4,538	4,202	4,202	3,57	13,80	LGBXS55	BL	
53	38,0	120	16,0	23,0	20,0	M 14	24,0	130,76	259,71	6,430	6,617	6,617	3,97	13,80	LGBXS55	BE	