

7.3 LGBCS...F

Linear guide with ball chain, carriage in flange design, flat design height

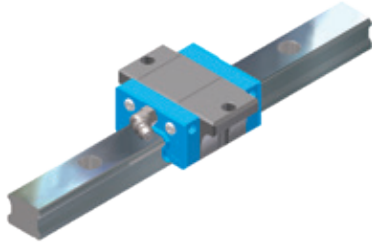

LGBCS...FS, short

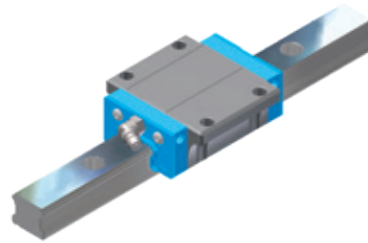

LGBCS...FN, standard

Example of order code

LGBCS 25 FN 2 SS L 02000 N Z1 - 2 - 0 -20.0 N*

*Explanation to type code in Chapter 8

	System mm						Carriage mm											
	H	W	W2	E	L	B	J	MQ	ih	I	L1	H2	T1	N	T2	L2	H3	Lx
LGBCS15 FS	24	52	18,5	3,4	40,6	41	--	M 5	4,4	7,5	22,2	M 3 x 0,5	5,5	5,7	4,5	4,20	M 3 x 0,5	3,0
LGBCS15 FN	24	52	18,5	3,4	58,6	41	26	M 5	4,4	7,5	40,2	M 3 x 0,5	5,5	5,7	4,5	4,20	M 3 x 0,5	3,0
LGBCS20 FS	28	59	19,5	4,5	49,1	49	--	M 6	5,4	7,0	27,5	M 6 x 1,0	5,1	12,3	4,3	4,25	M 6 x 1,0	3,8
LGBCS20 FN	28	59	19,5	4,5	70,1	49	32	M 6	5,4	7,0	48,5	M 6 x 1,0	5,1	12,3	4,3	4,25	M 6 x 1,0	3,8
LGBCS25 FS	33	73	25,0	5,8	54,0	60	--	M 8	6,8	7,1	32,3	M 6 x 1,0	7,2	12,2	6,4	4,65	M 6 x 1,0	5,0
LGBCS25 FN	33	73	25,0	5,8	79,2	60	35	M 8	6,8	7,1	57,5	M 6 x 1,0	7,2	12,2	6,4	4,65	M 6 x 1,0	5,0

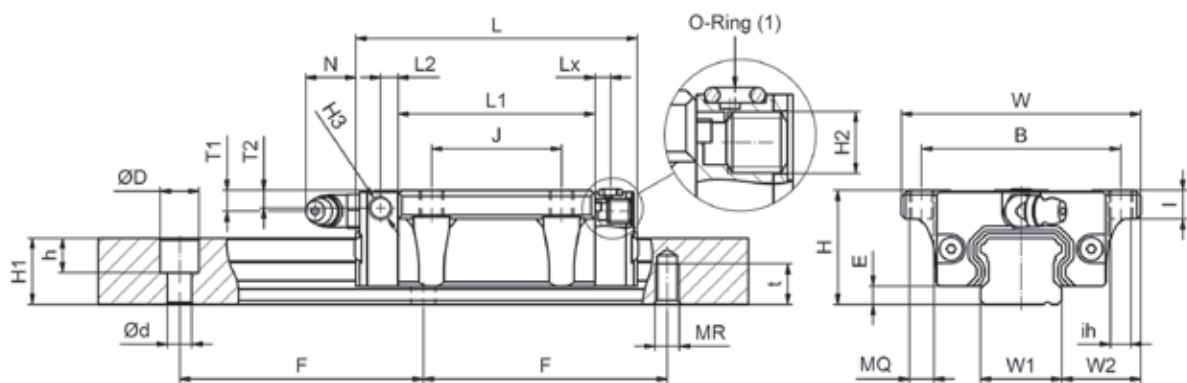
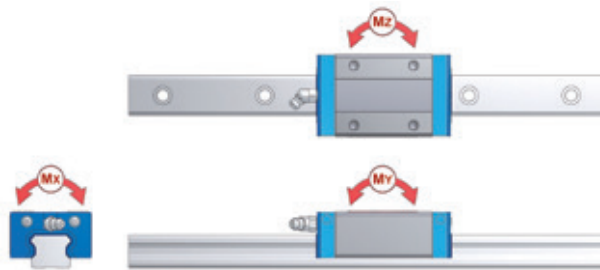

Rail [mm]								Load rating					Mass			
W1	H1	F	Version L			Version C		kN		kNm			kg	kg/ m		
			d	D	h	MR	t	C	C0	MX	MY	MZ	Carriage	Rail		
15	13	60	4,5	7,5	5,5	M 5	8,0	5,81	9,90	0,069	0,032	0,032	0,12	1,28	LGBCS15	FS
15	13	60	4,5	7,5	5,5	M 5	8,0	11,67	19,90	0,137	0,120	0,120	0,19	1,28	LGBCS15	FN
20	16,3	60	6,0	9,5	8,5	M 6	10,0	9,25	15,93	0,148	0,066	0,066	0,18	2,15	LGBCS20	FS
20	16,3	60	6,0	9,5	8,5	M 6	10,0	17,98	30,96	0,289	0,224	0,224	0,31	2,15	LGBCS20	FN
23	19,2	60	7,0	11,0	9,0	M 6	12,0	12,87	21,34	0,230	0,103	0,103	0,33	2,88	LGBCS25	FS
23	19,2	60	7,0	11,0	9,0	M 6	12,0	25,25	41,73	0,447	0,358	0,358	0,50	2,88	LGBCS25	FN