

### Outer ring and roller assembly with separable inner ring

Outer ring and roller assemblies and associated inner rings are packed and shipped separately. For a complete bearing, specify both outer and inner numbers desired.

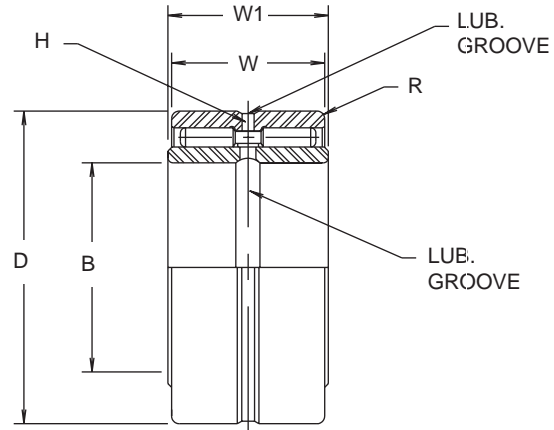

McGILL NUMBER outer ring & roller assy.	McGILL NUMBER inner ring only	ABMA NUMBER	B		D		W	W1	H	R	SHAFT DIA.				HSG. BORE DIA.				STATIC LOAD RATING (LBS.)	BASIC DYNAMIC RATING (LBS.)
			+ .0000	TOL.	+ .0000	TOL.	+ .00- 0 - .005	+ .00- 0 - .005	HOLE DIA.	MAX. FILLET for shaft & hsg.	ROTAT. SHAFT	TOL. + .000- 0	STAT. SHAF- T	TOL. + .0000	ROTAT. HSG.	TOL. + .0000	STAT. HSG.	TOL. + .0000		
GR-10-N	MI-6-N	6NAS1218	.3750	-.0004	1.1250	-.0005	.750	.760	5/64	.025	.3755	-.0005	.3747	-.0005	1.1247	-.0007	1.1257	-.0007	6400	3400
GR-10-N	MI-7-N	7NAS1218	.4375		1.1250		.750	.760	5/64	.025	.4380		.4372		1.1247		1.1257		6400	3400
GR-10	MI-6	6NAS1618	.3750		1.1250		1.000	1.010	5/64	.025	.3755		.3747		1.1247		1.1257		9100	4700
GR-12-N	MI-8-N	8NAS1220	.5000	-.0004	1.2500	-.0005	.750	.760	5/64	.040	.5005	-.0005	.4997	-.0005	1.2497	-.0007	1.2507	-.0007	7200	3700
GR-12-N	MI-9-N	9NAS1220	.5625		1.2500		.750	.760	5/64	.040	.5630		.5623		1.2497		1.2507		7200	3700
GR-12	MI-8	8NAS1620	.5000		1.2500		1.000	1.010	5/64	.040	.5005		.4997		1.2497		1.2507		10900	5100
GR-14-N	MI-10-N	10NAS1222	.6250	-.0004	1.3750	-.0005	.750	.760	5/64	.040	.6255	-.0005	.6247	-.0005	1.3747	-.0007	1.3757	-.0007	8400	4150
GR-14-N	MI-11-N	11NAS1222	.6875		1.3750		.750	.760	5/64	.040	.6880		.6872		1.3747		1.3757		8400	4150
GR-14	MI-10	10NAS1622	.6250		1.3750		1.000	1.010	5/64	.040	.6255		.6247		1.3747		1.3757		12800	5700
GR-16-N	MI-12-N	12NAS1224	.7500	-.0004	1.5000	-.0005	.750	.760	5/64	.040	.7505	-.0005	.7497	-.0005	1.4997	-.0007	1.5007	-.0007	9600	4350
GR-16-N	MI-13-N	13NAS1224	.8125		1.5000		.750	.760	5/64	.040	.8129		.8121		1.4997		1.5007		9600	4350
GR-16	MI-12	12NAS1624	.7500		1.5000		1.000	1.010	5/64	.040	.7505		.7497		1.4997		1.5007		14500	6050
GR-16	MI-13	13NAS1624	.8125	-.0004	1.5000	-.0005	1.000	1.010	5/64	.040	.8129	-.0005	.8121	-.0005	1.4997	-.0007	1.5007	-.0007	14500	6050
GR-18-N	MI-14-N	14NAS1626	.8750		1.6250		1.000	1.010	3/32	.040	.8754		.8746		1.6247		1.6257		15200	6250
GR-18-N	MI-15-N	15NAS1626	.9375		1.6250		1.000	1.010	3/32	.040	.9379		.9371		1.6247		1.6257		15200	6250
GR-18	MI-14	14NAS2026	.8750	-.0004	1.6250	-.0005	1.250	1.260	3/32	.040	.8754	-.0005	.8746	-.0005	1.6247	-.0007	1.6257	-.0007	20900	7900
GR-18	MI-15	15NAS2026	.9375		1.6250		1.250	1.260	3/32	.040	.9379		.9371		1.6247		1.6257		20900	7900
GR-18-N	MI-15-N	15NAS2026	.9375		1.6250		1.250	1.260	3/32	.040	.9379		.9371		1.6247		1.6257		20900	7900
GR-20-N	MI-16-N	16NAS1628	1.0000	-.0004	1.7500	-.0005	1.000	1.010	3/32	.040	1.0004	-.0005	.9996	-.0005	1.7497	-.0007	1.7507	-.0007	17000	6500
GR-20	MI-16	16NAS2028	1.0000		1.7500		1.250	1.260	3/32	.040	1.0004		.9996		1.7497		1.7507		23100	8300
GR-22-N	MI-18-N	18NAS1630	1.1250		1.8750		1.000	1.010	3/32	.040	1.1255		1.1246		1.8747		1.8757		18600	7100
GR-22	MI-17	17NAS2030	1.0625	-.0004	1.8750	-.0005	1.250	1.260	3/32	.040	1.0630	-.0005	1.0621	-.0005	1.8747	-.0007	1.8757	-.0007	25500	9050
GR-22	MI-18	18NAS2030	1.1250		1.8750		1.250	1.260	3/32	.040	1.1255		1.1246		1.8747		1.8757		25500	9050
GR-24-N	MI-20-N	20NAS1633	1.2500		2.0625		1.000	1.010	3/32	.060	1.2505		1.2496		2.0621		2.0632		20200	7150
GR-24	MI-19	19NAS2033	1.1875	-.0004	2.0625	-.0005	1.250	1.260	3/32	.060	1.1880	-.0005	1.1871	-.0005	2.0621	-.0007	2.0632	-.0007	27800	9150
GR-24	MI-20	20NAS2033	1.2500		2.0625		1.250	1.260	3/32	.060	1.2505		1.2496		2.0621		2.0632		27800	9150
GR-26-N	MI-21-N	21NAS1635	1.3125		2.1875		1.000	1.010	3/32	.060	1.3130		1.3121		2.1871		2.1882		21700	7500
GR-26	MI-21	21NAS2035	1.3125	-.0004	2.1875	-.0005	1.250	1.260	3/32	.060	1.3130	-.0005	1.3121	-.0005	2.1871	-.0007	2.1882	-.0007	29800	9600
GR-26	MI-22-4S	21NAS2035	1.3750		2.1875		1.250	1.260	3/32	.060	1.3755		1.3746		2.1871		2.1882		29800	9600
GR-28	MI-22	22NAS2037	1.3750		2.3125		1.250	1.260	3/32	.060	1.3755		1.3746		2.3121		2.3132		32100	9850
GR-28	MI-23	23NAS2037	1.4375	-.0004	2.3125	-.0005	1.250	1.260	3/32	.060	1.4380	-.0005	1.4371	-.0005	2.3121	-.0007	2.3132	-.0007	32100	9850
GR-28	MI-24	24NAS2037	1.5000		2.3125		1.250	1.260	3/32	.060	1.5005		1.4996		2.3121		2.3132		32100	9850

McGILL NUMBER outer ring & roller assy.	McGILL NUMBER inner ring only	ABMA NUMBER	B		D		W	W1	H	R	SHAFT DIA.			HSG. BORE DIA.				STATIC LOAD RATING (LBS.)	BASIC DYNAMIC RATING (LBS.)	
			+ .0000	TOL.	+ .0000	TOL.	+ .000 - .005	+ .000 - .005	HOLE DIA.	MAX. FILLET for shaft & hsg.	ROTAT. SHAFT	TOL. + .0000	STAT. SHAFT	TOL. + .0000	ROTAT. HSG.	TOL. + .0000	STAT. HSG.			TOL. + .0000
GR-30	MI-25-4S	25NAS2039	1.5625		2.4375		1.250	1.260	3/32	.060	1.5630		1.5621		2.4371		2.4382		34600	10450
GR-32-N	MI-26-N	26NAS1641	1.6250	-.0005	2.5625	-.0006	1.000	1.010	3/32	.060	1.6255	-.0005	1.6246	-.0005	2.5621	-.0007	2.5632	-.0007	26700	8000
GR-32	MI-25	25NAS2041	1.5625		2.5625		1.250	1.260	3/32	.060	1.5630		1.5621		2.5621		2.5632		36700	10250
GR-32	MI-26	26NAS2041	1.6250		2.5625		1.250	1.260	3/32	.060	1.6255		1.6246		2.5621		2.5632		36700	10250
GR-32	MI-27	27NAS2041	1.6875		2.5625		1.250	1.260	3/32	.060	1.6880		1.6871		2.5621		2.5632		36700	10250
GR-36-N	MI-28-N	28NAS2448	1.7500	-.0005	3.0000	-.0006	1.500	1.510	1/8	.060	1.7505	-.0005	1.7496	-.0005	2.9996	-.0007	3.0007	-.0007	49100	15250
GR-36	MI-28	28NAS2848	1.7500		3.0000		1.750	1.760	1/8	.060	1.7505		1.7496		2.9996		3.0007		60200	18450
GR-36	MI-30	30NAS2848	1.8750		3.0000		1.750	1.760	1/8	.060	1.8755		1.8746		2.9996		3.0007		60200	18450
GR-40-N	MI-32-N	32NAS2452	2.0000	-.0005	3.2500	-.0006	1.500	1.510	1/8	.080	2.0005	-.0005	1.9996	-.0005	3.2496	-.0007	3.2507	-.0007	54500	16200
GR-40	MI-31	31NAS2852	1.9375		3.2500		1.750	1.760	1/8	.080	1.9380		1.9371		3.2496		3.2507		66800	19800
GR-40	MI-32	32NAS2852	2.0000		3.2500		1.750	1.760	1/8	.080	2.0005		1.9996		3.2496		3.2507		66800	19800
GR-40	MI-34	34NAS2852	2.1250		3.2500		1.750	1.760	1/8	.080	2.1258		2.1247		3.2496		3.2507		66800	19800
GR-44-N	MI-36-N	36NAS2546	2.2500	-.0006	3.5000	-.0008	1.500	1.510	1/8	.080	2.2508	-.0008	2.2497	-.0008	3.4995	-.0010	3.5008	-.0010	59900	16800
GR-44	MI-35	35NAS2856	2.1875		3.5000		1.750	1.760	1/8	.080	2.1883		2.1872		3.4995		3.5008		73400	20350
GR-44	MI-36	36NAS2856	2.2500		3.5000		1.750	1.760	1/8	.080	2.2508		2.2497		3.4995		3.5008		73400	20350
GR-48-N	MI-40-N	40NAS2460	2.5000	-.0006	3.7500	-.0008	1.500	1.510	1/8	.080	2.5008	-.0008	2.4997	-.0008	3.7495	-.0010	3.7508	-.0010	65400	17350
GR-48	MI-38	38NAS2860	2.3750		3.7500		1.750	1.760	1/8	.080	2.3758		2.3747		3.7495		3.7508		80200	20600
GR-48	MI-39	39NAS2860	2.4375		3.7500		1.750	1.760	1/8	.080	2.4383		2.4372		3.7495		3.7508		80200	20600
GR-48	MI-40	40NAS2860	2.5000		3.7500		1.750	1.760	1/8	.080	2.5008		2.4997		3.7495		3.7508		80200	20600
GR-52	MI-42	42NAS2868	2.6250	-.0006	4.2500	-.0008	1.750	1.760	3/16	.080	2.6258	-.0008	2.6247	-.0010	4.2495	-.0010	4.2508	-.0010	80100	23950
GR-52	MI-44	44NAS2868	2.7500		4.2500		1.750	1.760	3/16	.080	2.7508		2.7497		4.2495		4.2508		80100	23950
GR-56-N	MI-48-N	48NAS2872	3.0000	-.0006	4.5000	-.0008	1.750	1.760	3/16	.080	3.0008	-.0008	2.9997	-.0010	4.4995	-.0015	4.5008	-.0015	86500	25100
GR-56	MI-46	46NAS3272	2.8750		4.5000		2.000	2.010	3/16	.080	2.8758		2.8747		4.4995		4.5008		104000	28900
GR-56	MI-47	47NAS3272	2.9375		4.5000		2.000	2.010	3/16	.080	2.9383		2.9372		4.4995		4.5008		104000	28900
GR-56	MI-48	48NAS3272	3.0000		4.5000		2.000	2.010	3/16	.080	3.0008		2.9997		4.4995		4.5008		104000	28900
GR-60	MI-50	50NAS3276	3.1250	-.0006	4.7500	-.0008	2.000	2.010	3/16	.100	3.1260	-.0010	3.1246	-.0010	4.7495	-.0015	4.7508	-.0015	111000	29300
GR-60	MI-52	52NAS3276	3.2500		4.7500		2.000	2.010	3/16	.100	3.2510		3.2496		4.7495		4.7508		111000	29300
GR-64	MI-54	54NAS3280	3.3750	-.0008	5.0000	-.0010	2.000	2.010	3/16	.100	3.3758	-.0010	3.3746	-.0010	4.9999	-.0015	5.0011	-.0015	119000	30100
GR-64	MI-56	56NAS3280	3.5000		5.0000		2.000	2.010	3/16	.100	3.5008		3.4996		4.9999		5.0011		119000	30100
GR-68	MI-58	58NAS3284	3.6250		5.2500		2.000	2.010	3/16	.100	3.6258		3.6246		5.2499		5.2511		126000	31500
GR-68	MI-60	60NAS3284	3.7500		5.2500		2.000	2.010	3/16	.100	3.7508		3.7496		5.2499		5.2511		126000	31500
GR-72	MI-62	62NAS3696	3.8750	-.0008	6.0000	-.0010	2.250	2.260	1/4	.100	3.8758	-.0010	3.8746	-.0010	5.9999	-.0015	6.0011	-.0015	145000	43400
GR-80	MI-64	64NAS36104	4.0000		6.5000		2.250	2.260	1/4	.100	4.0008		3.9996		6.4999		6.5011		161000	48800
GR-80	MI-68	68NAS36104	4.2500	6.5000	2.250	2.260	1/4	.100	4.2508	4.2496	6.4999	6.5011	161000	48800						
GR-88-N	MI-72-N	72NAS40112	4.5000	-.0010	7.0000	-.0012	2.500	2.515	1/4	.100	4.5008	-.0012	4.4996	-.0012	6.9999	-.0020	7.0011	-.0020	171000	60700
GR-88	MI-72	72NAS48112	4.5000		7.0000		3.000	3.015	1/4	.100	4.5008		4.4996		6.9999		7.0011		205000	65000
GR-96-N	MI-80-N	80NAS40120	5.0000	-.0010	7.5000	-.0012	2.500	2.515	1/4	.120	5.0010	-.0012	4.9995	-.0012	7.4998	-.0020	7.5011	-.0020	223000	65700
GR-96	MI-80	80NAS48120	5.0000		7.5000		3.000	3.015	1/4	.120	5.0010		4.9995		7.4998		7.5011		283000	71400
GR-104-N	MI-88-N	88NAS40128	5.5000	-.0010	8.0000	-.0012	2.500	2.515	1/4	.120	5.5010	-.0012	5.4995	-.0012	7.9998	-.0020	8.0011	-.0020	242000	68900
GR-104	MI-88	88NAS48128	5.5000		8.0000		3.000	3.015	1/4	.120	5.5010		5.4995		7.9998		8.0011		308000	75000
GR-116	MI-96	96NAS48146	6.0000	-.0012	9.1250	-.0014	3.000	3.015	1/4	.120	6.0012	-.0014	5.9995	-.0014	9.1248	-.0020	9.1261	-.0020	332000	83900
GR-124	MI-104	104NAS48154	6.5000		9.6250		3.000	3.015	1/4	.120	6.5012		6.4995		9.6250		9.6265		355000	86200
GR-132	MI-112	112NAS48162	7.0000	-.0012	10.1250	-.0014	3.000	3.015	1/4	.120	7.0012	-.0014	6.9995	-.0014	10.1250	-.0020	10.1265	-.0020	378000	88700
GR-140	MI-120	120NAS48170	7.5000		10.6250		3.000	3.015	1/4	.160	7.5010		7.4995		10.6250		10.6265		401000	91500
GR-148	MI-128	128NAS48170	8.0000	-.0012	11.1250	-.0014	3.000	3.015	1/4	.160	8.0010	-.0014	7.9995	-.0014	11.1250	-.0020	11.1265	-.0020	423000	93500

CAGEROL®/GUIDEROL® Bearings

### Outer ring and roller assembly without separable inner ring

The outer ring and roller assemblies (GR) shown in this table are for use without inner rings on a ground shaft for which a minimum hardness of 58 Rockwell "C" scale is recommended.

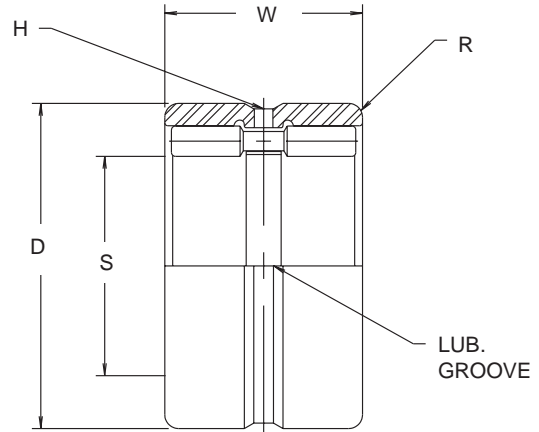

McGILL NUMBER outer ring & roller assy.	ABMA NUMBER	S SHAFT DIA.		D		W	H	R	HSG. BORE DIA.			STATIC LOAD RATING (LBS.)	BASIC DYNAMIC RATING (LBS.)	
		+0.000	TOL.	+0.000	TOL.	+0.000 -0.005	HOLE DIA.	MAX. FILLET FOR HOUSING	ROTATING HOUSING	TOL. +0.000	STATIONARY HOUSING			TOL. +0.000
GR-8-N	8NAR1216	.5000	-.0005	1.0000	-.0005	.750	5/64	.025	.9997	-0.0007	1.0007	-0.0007	4500	2600
GR-10-N	10NAR1218	.6250		1.1250		.750	5/64	.025	1.1247		1.1257		6400	3400
GR-10	10NAR1618	.6250		1.1250		1.000	5/64	.025	1.1247		1.1257		9100	4700
GR-12-N	12NAR1220	.7500		1.2500		.750	5/64	.040	1.2497		1.2507		7200	3700
GR-12	12NAR1620	.7500		1.2500		1.000	5/64	.040	1.2497		1.2507		10900	5100
GR-14-N	14NAR1222	.8750		1.3750		.750	5/64	.040	1.3747		1.3757		8400	4150
GR-14	14NAR1622	.8750		1.3750		1.000	5/64	.040	1.3747		1.3757		12800	5700
GR-16-N	16NAR1224	1.0000		1.5000		.750	5/64	.040	1.4997		1.5007		9600	4350
GR-16	16NAR1624	1.0000		1.5000		1.000	5/64	.040	1.4997		1.5007		14500	6050
GR-18-N	18NAR1626	1.1250		1.6250		1.000	3/32	.040	1.6247		1.6257		15200	6250
GR-18	18NAR2026	1.1250		1.6250		1.250	3/32	.040	1.6247		1.6257		20900	7900
GR-20-N	20NAR1628	1.2500		1.7500		1.000	3/32	.040	1.7497		1.7507		17000	6500
GR-20	20NAR2028	1.2500		1.7500		1.250	3/32	.040	1.7497		1.7507		23100	8300
GR-22-N	22NAR1630	1.3750		1.8750		1.000	3/32	.040	1.8747		1.8757		18600	7100
GR-22	22NAR2030	1.3750		1.8750		1.250	3/32	.040	1.8747		1.8757		25500	9050
GR-24-N	24NAR1633	1.5000		2.0625		1.000	3/32	.060	2.0621		2.0632		20200	7150
GR-24	24NAR2033	1.5000		2.0625		1.250	3/32	.060	2.0621		2.0632		27800	9150
GR-26-N	26NAR1635	1.6250		2.1875		1.000	3/32	.060	2.1871		2.1882		21700	7500
GR-26	26NAR2035	1.6250		2.1875		1.250	3/32	.060	2.1871		2.1882		29800	9600
GR-28	28NAR2037	1.7500		2.3125		1.250	3/32	.060	2.3121		2.3132		32100	9850
GR-30	30NAR2039	1.8750	2.4375	1.250	3/32	.060	2.4371	2.4382	34600	10450				
GR-32-N	32NAR1641	2.0000	2.5625	1.000	3/32	.060	2.5621	2.5632	26700	8000				
GR-32	32NAR2041	2.0000	2.5625	1.250	3/32	.060	2.5621	2.5632	36700	10250				
GR-36-N	36NAR2448	2.2500	3.0000	1.500	1/8	.060	2.9996	3.0007	49100	15250				
GR-36	36NAR2848	2.2500	3.0000	1.750	1/8	.060	2.9996	3.0007	60200	18450				
GR-40-N	40NAR2452	2.5000	3.2500	1.500	1/8	.080	3.2496	3.2507	54500	16200				
GR-40	40NAR2852	2.5000	3.2500	1.750	1/8	.080	3.2496	3.2507	66800	19800				
GR-44-N	44NAR2456	2.7500	3.5000	1.500	1/8	.080	3.4995	3.5008	59900	16800				
GR-44	44NAR2856	2.7500	3.5000	1.750	1/8	.080	3.4995	3.5008	73400	20350				
GR-48-N	48NAR2460	3.0000	3.7500	1.500	1/8	.080	3.7495	3.7508	65400	17350				
GR-48	48NAR2860	3.0000	3.7500	1.750	1/8	.080	3.7495	3.7508	80200	20600				
GR-52	52NAR2868	3.2500	4.2500	1.750	3/16	.080	4.2495	4.2508	80100	23950				
GR-56-N	56NAR2872	3.5000	4.5000	1.750	3/16	.080	4.4995	4.5008	86500	25100				
GR-56	56NAR3272	3.5000	4.5000	2.000	3/16	.080	4.4995	4.5008	104000	28900				
GR-60	60NAR3276	3.7500	4.7500	2.000	3/16	.100	4.7495	4.7508	111000	29300				
GR-64	64NAR3280	4.0000	5.0000	2.000	3/16	.100	4.9999	5.0011	119000	30900				
GR-68	68NAR3284	4.2500	5.2500	2.000	3/16	.100	5.2499	5.2511	126000	31500				
GR-72	72NAR3696	4.5000	6.0000	2.250	1/4	.100	5.9999	6.0011	145000	43400				
GR-80	80NAR36104	5.0000	6.5000	2.250	1/4	.100	6.4999	6.5011	161000	48800				
GR-88-N	88NAR40112	5.5000	7.0000	2.500	1/4	.100	6.9999	7.0011	171000	60700				
GR-88	88NAR48112	5.5000	7.0000	3.000	1/4	.100	6.9999	7.0011	205000	65000				
GR-96-N	96NAR40120	6.0000	7.5000	2.500	1/4	.120	7.4998	7.5011	223000	65700				
GR-96	96NAR48120	6.0000	7.5000	3.000	1/4	.120	7.4998	7.5011	283000	71400				
GR-104-N	104NAR40128	6.5000	8.0000	2.500	1/4	.120	7.9998	8.0011	242000	68900				
GR-104	104NAR48128	6.5000	8.0000	3.000	1/4	.120	7.9998	8.0011	308000	75000				
GR-116	116NAR48146	7.2500	9.1250	3.000	1/4	.120	9.1248	9.1261	332000	83900				
GR-124	124NAR48154	7.7500	9.6250	3.000	1/4	.120	9.6250	9.6265	355000	86200				
GR-132	132NAR48162	8.2500	10.1250	3.000	1/4	.120	10.1250	10.1265	378000	88700				
GR-140	140NAR48170	8.7500	10.6250	3.000	1/4	.160	10.6250	10.6265	401000	91500				
GR-148	148NAR48178	9.2500	11.1250	3.000	1/4	.160	11.1250	11.1265	423000	93500				

NOTE: Some larger sizes not available from stock. Consult McGill Customer Service for availability.