

McGILL® TRAKROL Cam Follower Bearings

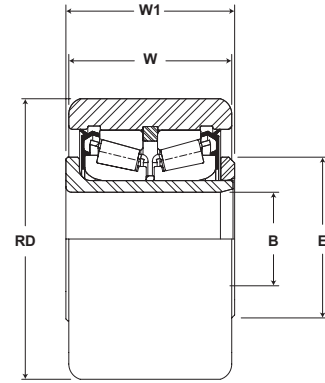

- Basic Construction Type:** Yoke Type Cylindrical Outside Diameter
- Rolling Elements:** Ball or Tapered Roller Bearing Insert
- Bearing Material:** Bearing Quality Steel
- Seal Type:** Rubber Lip
- Lubrication:** Polyurea Thickened Grease NLGI #2



PCYR

Part No.	Insert Type	RD	W	B		W1	E	Track Roller Dynamic Rating	Thrust Capacity	Track Roller Static Rating	WT
		Roller Diameter	Roller Width	Bore Diameter		Endplate Extension	Min. Clamping Diameter				Bearing Weight
		inch mm		inch mm		inch mm					lb/N
		(Ref)	(Ref)	Nom.	Tol.	(Ref)	(Ref)				
PCYR 3	TRB	3.00 76.2	1.75 44.5	1.000 25.40	+0.0007 /-0 +0.02 / - 0	1.81 46.0	1.75 44.5	14,300 63,606	5,790 25,754	20,000 88,960	2.57 1.17
PCYR 3 1/2	TRB	3.50 88.9	2.00 50.8	1.125 28.58	+0.0007 /-0 +0.02 / - 0	2.06 52.4	2.00 50.8	14,300 63,606	5,790 25,754	27,200 120,986	4.41 2.00
PCYR 4	TRB	4.00 101.6	2.25 57.2	1.250 31.75	+0.0007 /-0 +0.02 / - 0	2.31 58.7	2.25 57.2	14,300 63,606	5,790 25,754	27,200 120,986	6.57 2.98
PCYR 4 1/2	TRB	4.50 114.3	1.75 44.5	1.000 25.40	+0.0007 /-0 +0.02 / - 0	1.81 46.0	1.75 44.5	14,300 63,606	5,790 25,754	20,000 88,960	9.09 4.12
PCYR 5	TRB	5.00 127.0	3.75 95.3	1.750 44.45	+0.0007 /-0 +0.02 / - 0	2.85 72.3	3.00 76.2	35,800 159,238	13,300 59,158	58,400 259,763	11.61 5.27
PCYR 6	TRB	6.00 152.4	3.25 82.6	2.250 57.15	+0.0007 /-0 +0.02 / - 0	3.38 85.7	3.25 82.6	35,800 159,238	14,200 63,162	58,400 259,763	20.47 9.29

*Dynamic thrust load rating based on application of a centric, axial load. Fatigue life calculations for combined radial and thrust loading require special considerations and Application Engineering should be contacted.

Metric dimensions for reference only.

Not all parts are available from stock. Please contact customer service for availability (800) 626-2120.

For more information on bearing capabilities outside of our standard offering, please contact Application Engineering (800) 626-2093.