

MCGILL® Metric CAMROL Bearings

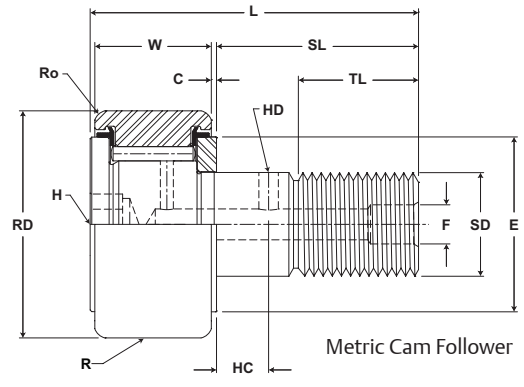

- Basic Construction Type:** Stud Type Crowned / Cylindrical Outside Diameter
- Rolling Elements:** Full Complement / Retained (Caged) Needle Roller
- Bearing Material:** Bearing Quality Steel
- Seal Type:** LUBRI-DISC®
- Lubrication:** Lithium Soap Grease NLGI #2
- System Configuration:** Concentric / Eccentric
- Mounting Feature:** Slot / Hex Hole



MCF, MCFE

Part No.		RD		W		SD		SL	C	TL	L	R	ECC	G	BD	Track Roller Dynamic Rating	Track Roller Static Rating
W/O Seals	With LUBRI-DISC Seals	Roller Diameter		Roller Width		Stud Diameter		Stud Length	Endplate Extension	Minimum Thread Length	Length Overall	Cylindrical	Eccentric				
		mm inch		mm inch		mm inch		mm inch	mm inch	mm inch	mm inch	mm inch	Base Modifier MCFE-xx				
		Nom.	Tol.	Nom.	Tol.	Nom.	Tol.	(Ref)	(Ref)	(Ref)	(Ref)	Radius	(Ref)	+05/- .15 + .002/- .006	(Ref)		
MCF 35	MCF 35 S	35.000 1.3780	+0/- .050 +0/- .002	18.000 .7087	+0/- .12 +0/- .005	16.000 .6299	+0/- .018 +0/- .0007	33 1.3	.80 .031	18.0 .71	52 2.0	500 19.7	N/A	N/A	N/A	16,970 3,815	28,500 6,407
MCF 35 B	MCF 35 SB		Cylindrical														
MCF 35 X	MCF 35 SX																
MCF 35 BX	MCF 35 SBX																
MCFE 35	MCFE 35 S	35.000 1.3780	+0/- .050 +0/- .002	18.000 .7087	+0/- .12 +0/- .005	16.000 .6299	+0/- .018 +0/- .0007	33 1.3	.80 .031	18.0 .71	52 2.0	500 19.7	0.5 .02	14 0.55	20 .79	16,970 3,815	28,500 6,407
MCFE 35 B	MCFE 35 SB		Cylindrical														
MCFE 35 X	MCFE 35 SX																
MCFE 35 BX	MCFE 35 SBX																
MCFR 35	MCFR 35 S	35.000 1.3780	+0/- .050 +0/- .002	18.000 .7087	+0/- .12 +0/- .005	16.000 .6299	+0/- .018 +0/- .0007	33 1.3	.80 .031	18.0 .71	52 2.0	500 19.7	N/A	N/A	N/A	10,890 2,448	15,900 3,575
MCFR 35 B	MCFR 35 SB		Cylindrical														
MCFR 35 X	MCFR 35 SX																
MCFR 35 BX	MCFR 35 SBX																
MCFRE 35	MCFRE 35 S	35.000 1.3780	+0/- .050 +0/- .002	18.000 .7087	+0/- .12 +0/- .005	16.000 .6299	+0/- .018 +0/- .0007	33 1.3	.80 .031	18.0 .71	52 2.0	500 19.7	0.5 .02	14 0.55	20 .79	10,890 2,448	15,900 3,575
MCFRE 35 B	MCFRE 35 SB		Cylindrical														
MCFRE 35 X	MCFRE 35 SX																
MCFRE 35 BX	MCFRE 35 SBX																
MCF 40	MCF 40 S	40.000 1.5748	+0/- .050 +0/- .002	20.000 .7874	+0/- .12 +0/- .005	18.000 .7087	+0/- .018 +0/- .0007	37 1.4	.80 .031	19.0 .75	58 2.3	500 19.7	N/A	N/A	N/A	19,420 4,366	32,200 7,239
MCF 40 B	MCF 40 SB		Cylindrical														
MCF 40 X	MCF 40 SX																
MCF 40 BX	MCF 40 SBX																
MCFE 40	MCFE 40 S	40.000 1.5748	+0/- .050 +0/- .002	20.000 .7874	+0/- .12 +0/- .005	18.000 .7087	+0/- .018 +0/- .0007	37 1.4	.80 .031	19.0 .75	58 2.3	500 19.7	1 .04	16 0.63	22 .87	19,420 4,366	32,200 7,239
MCFE 40 B	MCFE 40 SB		Cylindrical														
MCFE 40 X	MCFE 40 SX																
MCFE 40 BX	MCFE 40 SBX																
MCFR 40	MCFR 40 S	40.000 1.5748	+0/- .050 +0/- .002	20.000 .7874	+0/- .12 +0/- .005	18.000 .7087	+0/- .018 +0/- .0007	37 1.4	.80 .031	19.0 .75	58 2.3	500 19.7	N/A	N/A	N/A	13,340 2,999	19,800 4,451
MCFR 40 B	MCFR 40 SB		Cylindrical														
MCFR 40 X	MCFR 40 SX																
MCFR 40 BX	MCFR 40 SBX																
MCFRE 40	MCFRE 40 S	40.000 1.5748	+0/- .050 +0/- .002	20.000 .7874	+0/- .12 +0/- .005	18.000 .7087	+0/- .018 +0/- .0007	37 1.4	.80 .031	19.0 .75	58 2.3	500 19.7	1 .04	16 0.63	22 .87	13,340 2,999	19,800 4,451
MCFRE 40 B	MCFRE 40 SB		Cylindrical														
MCFRE 40 X	MCFRE 40 SX																
MCFRE 40 BX	MCFRE 40 SBX																

1. Standard bearing has a crowned roller outside diameter. For straight cylindrical outside roller diameter, add suffix "X". Example - MCFR-35-X or MCF-35-SX.
 2. Clamping torque is based on dry threads. If threads are lubricated, use half of value shown.
 3. Static load rating is based on stud strength or on internal rolling element load distribution stresses.
 4. Dynamic load should not exceed 50% of Dynamic Rating as a track roller.
 5. Since load, lubrication method, temperature and other factors affect the maximum operating speed, it is impossible to determine precise limiting speed. The listed limiting speeds are based on lightly loaded bearings having adequate lubrication and are listed only as a design guide. More frequent relubrication is required when operating at higher speeds. Actual bearing testing in the specific application should be conducted if the anticipated operating speed approaches the listed limiting speed.

Inch dimensions for reference only.
 Not all parts are available from stock. Please contact customer service for availability (800) 626-2120.
 For more information on bearing capabilities outside of our standard offering, please contact Application Engineering (800) 626-2093.

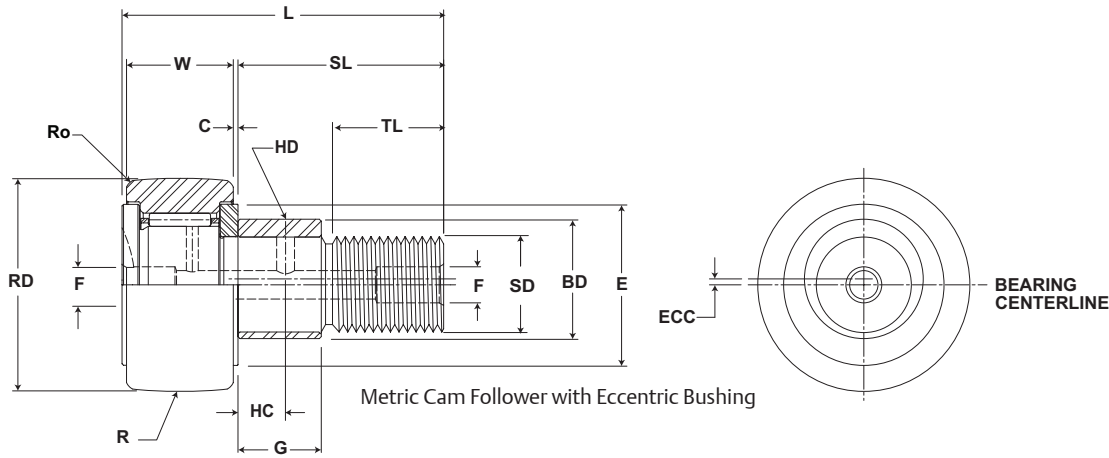

MCF, MCFE

Part No.		HC	HD	F	H	Ro	E	Housing Bore Diameter		Thread Type	Clamping Torque	Limiting Speed (Grease)	WT		
W/O Seals	With LUBRI-DISC Seals	Hole Center	Radial Lub. Hole Diameter	Lub. Hole Dia	Hex Hole Suffix MCF_xx B	Outer Corner	Min. Clamping Diameter							Nm in-lb	RPM
		(Ref)	(Ref)	(Ref)	(Ref)	(Ref)	(Ref)	Nom.	Tol.						
MCF 35	MCF 35 S	.315	.118	6/24	N/A	1.0	24	16.000	+.018/-0	M16x1.5	85	4,200	.16		
MCF 35 B	MCF 35 SB			-	8/31									.6299	+0.0007/-0
MCF 35 X	MCF 35 SX			6/24	N/A										
MCF 35 BX	MCF 35 SBX			-	8/31										
MCFE 35	MCFE 35 S	N/A	N/A	6/24	N/A	1.0	24	20.050	+0.025/-0	M16x1.5	85	4,200	.16		
MCFE 35 B	MCFE 35 SB			-	8/31									.7894	+0.0009/-0
MCFE 35 X	MCFE 35 SX			6/24	N/A										
MCFE 35 BX	MCFE 35 SBX			-	8/31										
MCFR 35	MCFR 35 S	.315	.118	6/24	N/A	1.0	24	16.000	+.018/-0	M16x1.5	85	6,300	.16		
MCFR 35 B	MCFR 35 SB			-	8/31									.6299	+0.0007/-0
MCFR 35 X	MCFR 35 SX			6/24	N/A										
MCFR 35 BX	MCFR 35 SBX			-	8/31										
MCFRE 35	MCFRE 35 S	N/A	N/A	6/24	N/A	1.0	24	20.050	+0.025/-0	M16x1.5	85	6,300	.16		
MCFRE 35 B	MCFRE 35 SB			-	8/31									.7894	+0.0009/-0
MCFRE 35 X	MCFRE 35 SX			6/24	N/A										
MCFRE 35 BX	MCFRE 35 SBX			-	8/31										
MCF 40	MCF 40 S	.315	.118	6/24	N/A	1.5	27	18.000	+.018/-0	M18x1.5	85	3,300	.25		
MCF 40 B	MCF 40 SB			-	8/31									.7087	+0.0007/-0
MCF 40 X	MCF 40 SX			6/24	N/A										
MCF 40 BX	MCF 40 SBX			-	8/31										
MCFE 40	MCFE 40 S	N/A	N/A	6/24	N/A	1.5	27	22.050	+0.025/-0	M18x1.5	85	3,300	.25		
MCFE 40 B	MCFE 40 SB			-	8/31									.8681	+0.0009/-0
MCFE 40 X	MCFE 40 SX			6/24	N/A										
MCFE 40 BX	MCFE 40 SBX			-	8/31										
MCFR 40	MCFR 40 S	.315	.118	6/24	N/A	1.5	27	18.000	+.018/-0	M18x1.5	85	5,000	.25		
MCFR 40 B	MCFR 40 SB			-	8/31									.7087	+0.0007/-0
MCFR 40 X	MCFR 40 SX			6/24	N/A										
MCFR 40 BX	MCFR 40 SBX			-	8/31										
MCFRE 40	MCFRE 40 S	N/A	N/A	6/24	N/A	1.5	27	22.050	+0.025/-0	M18x1.5	85	5,000	.25		
MCFRE 40 B	MCFRE 40 SB			-	8/31									.8681	+0.0009/-0
MCFRE 40 X	MCFRE 40 SX			6/24	N/A										
MCFRE 40 BX	MCFRE 40 SBX			-	8/31										

MCGILL® Metric CAMROL Bearings



- Basic Construction Type:** Stud Type Crowned / Cylindrical Outside Diameter
- Rolling Elements:** Full Complement / Retained (Caged) Needle Roller
- Bearing Material:** Bearing Quality Steel
- Seal Type:** LUBRI-DISC®
- Lubrication:** Lithium Soap Grease NLGI #2
- System Configuration:** Concentric / Eccentric
- Mounting Feature:** Slot / Hex Hole

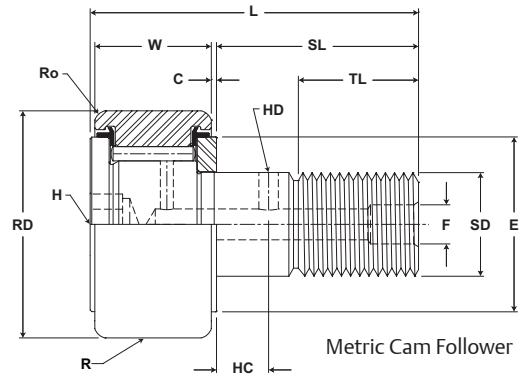

MCF, MCFE

Part No.		RD		W		SD		SL	C	TL	L	R	ECC	G	BD	Track Roller Dynamic Rating	Track Roller Static Rating		
W/O Seals	With LUBRI-DISC Seals	Roller Diameter		Roller Width		Stud Diameter		Stud Length	Endplate Extension	Minimum Thread Length	Length Overall	Cylindrical	Eccentric						
		mm inch		mm inch		mm inch		mm inch	mm inch	mm inch	mm inch	Suffix MCF-xx-X	Base Modifier MCFE-xx						
		Nom.	Tol.	Nom.	Tol.	Nom.	Tol.	(Ref)	(Ref)	(Ref)	(Ref)	Radius	(Ref)	+05/- .15 +.002/- .006	(Ref)				
MCF 40A	MCF 40A S	40.000 1.5748	+0/- .050 +0/- .002	20.000 +0/- .12 .7874 +0/- .005	18.000 +0/- .018 .7087 +0/- .0007	37	.80	20.0	58	19.7	58	2.3	N/A	N/A	N/A	19,420	32,200		
MCF 40A B	MCF 40A SB		+0/- .011 +0/- .0004															Cylindrical	
MCF 40A X	MCF 40A SX																		
MCF 40A BX	MCF 40A SBX																		
MCFE 40A	MCFE 40A S	40.000 1.5748	+0/- .050 +0/- .002	20.000 +0/- .12 .7874 +0/- .005	18.000 +0/- .018 .7087 +0/- .0007	37	.80	20.0	58	19.7	58	2.3	1	.04	16	.63	22	.87	
MCFE 40A B	MCFE 40A SB		+0/- .011 +0/- .0004																Cylindrical
MCFE 40A X	MCFE 40A SX																		
MCFE 40A BX	MCFE 40A SBX																		
MCFR 40A	MCFR 40A S	40.000 1.5748	+0/- .050 +0/- .002	20.000 +0/- .12 .7874 +0/- .005	18.000 +0/- .018 .7087 +0/- .0007	37	.80	20.0	58	19.7	58	2.3	N/A	N/A	N/A	13,340	19,800		
MCFR 40A B	MCFR 40A SB		+0/- .011 +0/- .0004															Cylindrical	
MCFR 40A X	MCFR 40A SX																		
MCFR 40A BX	MCFR 40A SBX																		
MCFRE 40A	MCFRE 40A S	40.000 1.5748	+0/- .050 +0/- .002	20.000 +0/- .12 .7874 +0/- .005	18.000 +0/- .018 .7087 +0/- .0007	37	.80	20.0	58	19.7	58	2.3	1	.04	16	.63	22	.87	
MCFRE 40A B	MCFRE 40A SB		+0/- .011 +0/- .0004																Cylindrical
MCFRE 40A X	MCFRE 40A SX																		
MCFRE 40A BX	MCFRE 40A SBX																		
MCF 47	MCF 47 S	47.000 1.8504	+0/- .050 +0/- .002	24.000 +0/- .12 .9449 +0/- .005	20.000 +0/- .021 .7874 +0/- .0008	41	.80	21.0	66	19.7	66	2.6	N/A	N/A	N/A	25,690	46,700		
MCF 47 B	MCF 47 SB		+0/- .011 +0/- .0004															Cylindrical	
MCF 47 X	MCF 47 SX																		
MCF 47 BX	MCF 47 SBX																		
MCFE 47	MCFE 47 S	47.000 1.8504	+0/- .050 +0/- .002	24.000 +0/- .12 .9449 +0/- .005	20.000 +0/- .021 .7874 +0/- .0008	41	.80	21.0	66	19.7	66	2.6	1	.04	18	.71	24	.94	
MCFE 47 B	MCFE 47 SB		+0/- .011 +0/- .0004																Cylindrical
MCFE 47 X	MCFE 47 SX																		
MCFE 47 BX	MCFE 47 SBX																		
MCFR 47	MCFR 47 S	47.000 1.8504	+0/- .050 +0/- .002	24.000 +0/- .12 .9449 +0/- .005	20.000 +0/- .021 .7874 +0/- .0008	41	.80	21.0	66	19.7	66	2.6	N/A	N/A	N/A	17,750	29,800		
MCFR 47 B	MCFR 47 SB		+0/- .011 +0/- .0004															Cylindrical	
MCFR 47 X	MCFR 47 SX																		
MCFR 47 BX	MCFR 47 SBX																		
MCFRE 47	MCFRE 47 S	47.000 1.8504	+0/- .050 +0/- .002	24.000 +0/- .12 .9449 +0/- .005	20.000 +0/- .021 .7874 +0/- .0008	41	.80	21.0	66	19.7	66	2.6	1	.04	18	.71	24	.94	
MCFRE 47 B	MCFRE 47 SB		+0/- .011 +0/- .0004																Cylindrical
MCFRE 47 X	MCFRE 47 SX																		
MCFRE 47 BX	MCFRE 47 SBX																		

1. Standard bearing has a crowned roller outside diameter. For straight cylindrical outside roller diameter, add suffix "X". Example - MCFR-35-X or MCF-35-SX.
 2. Clamping torque is based on dry threads. If threads are lubricated, use half of value shown.
 3. Static load rating is based on stud strength or on internal rolling element load distribution stresses.
 4. Dynamic load should not exceed 50% of Dynamic Rating as a track roller.
 5. Since load, lubrication method, temperature and other factors affect the maximum operating speed, it is impossible to determine precise limiting speed. The listed limiting speeds are based on lightly loaded bearings having adequate lubrication and are listed only as a design guide. More frequent relubrication is required when operating at higher speeds. Actual bearing testing in the specific application should be conducted if the anticipated operating speed approaches the listed limiting speed.

Inch dimensions for reference only.
 Not all parts are available from stock. Please contact customer service for availability (800) 626-2120.
 For more information on bearing capabilities outside of our standard offering, please contact Application Engineering (800) 626-2093.

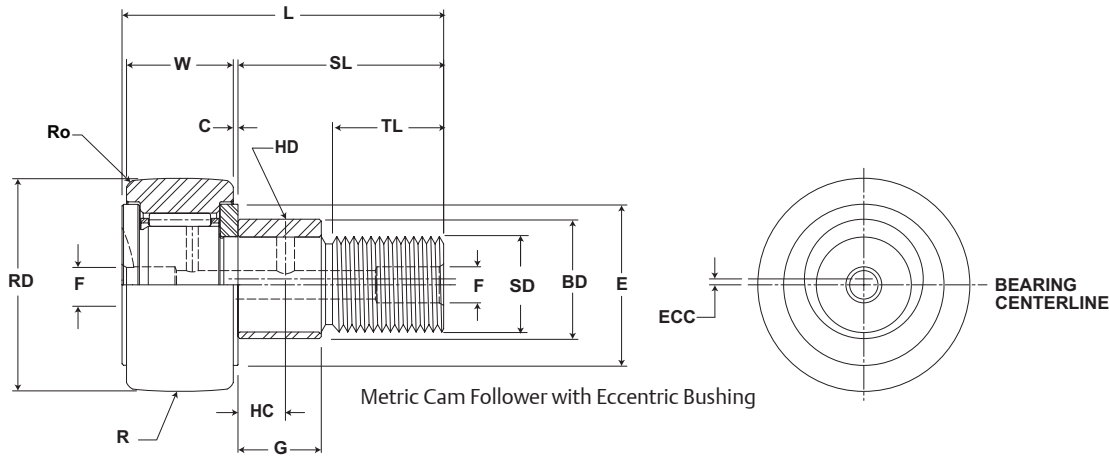

MCF, MCFE

Part No.		HC	HD	F	H	Ro	E	Housing Bore Diameter		Thread Type	Clamping Torque	Limiting Speed (Grease)	WT
W/O Seals	With LUBRI-DISC Seals	Hole Center	Radial Lub. Hole Diameter	Lub. Hole Dia	Hex Hole Suffix MCF_xx B	Outer Corner	Min. Clamping Diameter						
		mm inch	mm inch	mm inch	mm inch	mm inch	mm inch	Nom.	Tol.				
(Ref)	(Ref)	(Ref)	(Ref)	(Ref)	(Ref)	(Ref)	(Ref)						
MCF 40A	MCF 40A S			$\frac{6}{24}$	N/A					M18x1.5	118 1,044	3,300	.25 .55
MCF 40A B	MCF 40A SB	10	3	-	$\frac{8}{31}$	1.5	27	18.000	+0.018/-0				
MCF 40A X	MCF 40A SX	.394	.118	$\frac{6}{24}$	N/A	.06	1.1	.7087	+0.0007/-0				
MCF 40A BX	MCF 40A SBX			-	$\frac{8}{31}$								
MCFE 40A	MCFE 40A S			$\frac{6}{24}$	N/A					M18x1.5	118 1,044	3,300	.25 .55
	MCFE 40A SB	N/A	N/A	-	$\frac{8}{31}$	1.5	27	22.050	+0.025/-0				
	MCFE 40A SX			$\frac{6}{24}$	N/A	.06	1.1	.8681	+0.0009/-0				
	MCFE 40A SBX			-	$\frac{8}{31}$								
MCFR 40A	MCFR 40A S			$\frac{6}{24}$	N/A					M18x1.5	118 1,044	5,000	.25 .55
MCFR 40A B	MCFR 40A SB	10	3	-	$\frac{8}{31}$	1.5	27	18.000	+0.018/-0				
MCFR 40A X	MCFR 40A SX	.394	.118	$\frac{6}{24}$	N/A	.06	1.1	.7087	+0.0007/-0				
MCFR 40A BX	MCFR 40A SBX			-	$\frac{8}{31}$								
MCFRE 40A	MCFRE 40A S			$\frac{6}{24}$	N/A					M18x1.5	118 1,044	5,000	.25 .55
	MCFRE 40A SB	N/A	N/A	-	$\frac{8}{31}$	1.5	27	22.050	+0.025/-0				
	MCFRE 40A SX			$\frac{6}{24}$	N/A	.06	1.1	.8681	+0.0009/-0				
	MCFRE 40A SBX			-	$\frac{8}{31}$								
MCF 47	MCF 47 S			$\frac{8}{31}$	N/A					M20x1.5	118 1,044	2,600	.39 .86
MCF 47 B	MCF 47 SB	9	4	-	$\frac{10}{39}$	1.5	30	20.000	+0.021/-0				
MCF 47 X	MCF 47 SX	.354	.157	$\frac{8}{31}$	N/A	.06	1.2	.7874	+0.0008/-0				
MCF 47 BX	MCF 47 SBX			-	$\frac{10}{39}$								
MCFE 47	MCFE 47 S			$\frac{8}{31}$	N/A					M20x1.5	118 1,044	2,600	.39 .86
	MCFE 47 SB	N/A	N/A	-	$\frac{10}{39}$	1.5	30	24.050	+0.025/-0				
	MCFE 47 SX			$\frac{8}{31}$	N/A	.06	1.2	.9469	+0.0009/-0				
	MCFE 47 SBX			-	$\frac{10}{39}$								
MCFR 47	MCFR 47 S			$\frac{8}{31}$	N/A					M20x1.5	118 1,044	3,900	.39 .86
MCFR 47 B	MCFR 47 SB	9	4	-	$\frac{10}{39}$	1.5	30	20.000	+0.021/-0				
MCFR 47 X	MCFR 47 SX	.354	.157	$\frac{8}{31}$	N/A	.06	1.2	.7874	+0.0008/-0				
MCFR 47 BX	MCFR 47 SBX			-	$\frac{10}{39}$								
MCFRE 47	MCFRE 47 S			$\frac{8}{31}$	N/A					M20x1.5	118 1,044	3,900	.39 .86
	MCFRE 47 SB	N/A	N/A	-	$\frac{10}{39}$	1.5	30	24.050	+0.025/-0				
	MCFRE 47 SX			$\frac{8}{31}$	N/A	.06	1.2	.9469	+0.0009/-0				
	MCFRE 47 SBX			-	$\frac{10}{39}$								