



COM-M SERIES SPHERICAL BEARINGS - METRIC

(PTFE Liners Available)¹

timkenaurorabearing.com • Fax 630-859-0971

METRIC

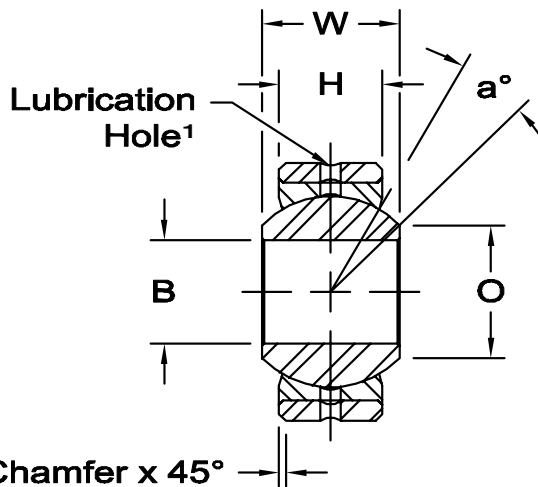
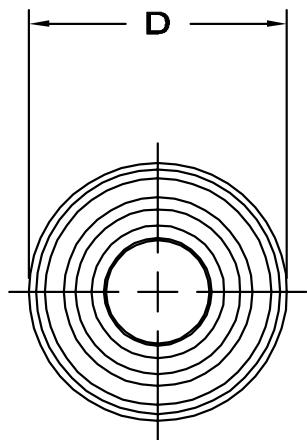

M Chamfer x 45°



Outer Member - Low carbon steel, protective coated for corrosion resistance.

Race - Low carbon steel, I.D. protective coated for corrosion resistance.

Ball - Alloy steel, heat treated, hard chrome plated.

* Check for availability.

¹ PTFE Liners use suffix T Ex: COM-M10T. PTFE lined parts do not have lubrication groove in outer member.

² Based upon maximum permanent set of .5% of ball O.D. (See page 5)

‡ Size 16 consists of ball & race only

BEARING NO.	DIMENSIONS IN MILLIMETERS							a° Misalign. Angle	Radial Static Limit Load Capacity Newtons ²	Approx. Brg. Wt. Grams
	B + .065 - .013	D + .000 - .018	H ± .13	W ± .13	O Flat Dia Ref.	M Chamfer Ref.	Ball Dia Ref.			
* COM-M3	3	12	4.50	6	5.19	.5	7.93	13.5	14,758	4
* COM-M5	5	16	6.00	8	7.68	.5	11.10	12.5	27,555	9
COM-M6	6	18	6.75	9	8.93	.5	12.70	12.5	35,459	13
COM-M8	8	22	9.00	12	10.35	.8	15.88	14	59,121	24
COM-M10	10	26	10.50	14	12.88	.8	19.05	13.5	82,744	40
COM-M12	12	30	12.00	16	15.39	.8	22.23	13	112,829	80
COM-M14	14	34	13.50	19	16.86	1.0	25.40	16	141,845	110
‡ COM-M16	16	38	15.00	21	19.34	1.0	28.58	15	177,343	130
* COM-M18	18	42	16.50	23	21.89	1.0	31.75	15	216,714	170
COM-M20	20	46	18.00	25	24.35	1.0	34.93	14.5	260,086	230
* COM-M22	22	50	20.00	28	25.84	1.5	38.10	15	315,216	280
* COM-M25	25	56	22.00	31	29.60	1.5	42.86	15	390,056	390
* COM-M30	30	66	25.00	37	34.81	1.5	50.80	17	525,360	610

For suggested housing bores, see page 111