

CW-M & CG-M SERIES FEMALE ROD ENDS - METRIC

General Purpose - Economy



Body - Low carbon steel, protective coated for corrosion resistance.

Ball - Alloy steel, heat treated, hard chrome plated.

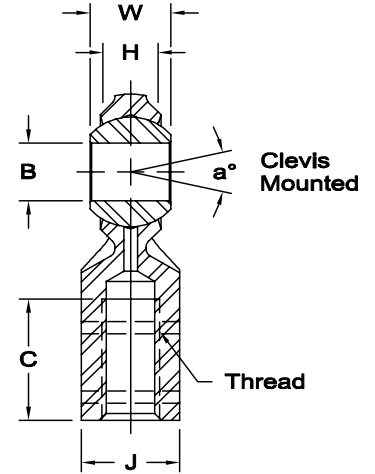
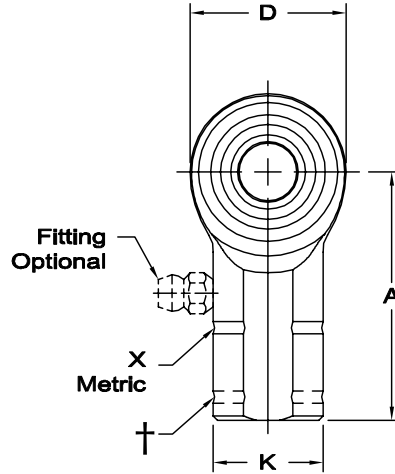

*Check for availability. ** See page 5.
X Designates metric threads.

Z Zerk type fitting - CW-M10Z
(Not available for 3 & 5)

†Left hand units have identification groove near the end of shank.

ROD END NO.		DIMENSIONS IN MILLIMETERS										a°			Ultimate Radial Static Load Capacity Newtons	Approx. Brg. Wt. Grams
Right Hand	Left Hand†	B +.065 -.013	W ± .13	H Ref.	A ± .40	D Ref.	K ± .25	J ± .25	Ball Dia. Ref.	C ± 1.00	Thread	Misalign. Angle**				
												a ₁	a ₃	a ₄		
* CW-M3	CG-M3	3	6	4.25	21	12.50	8	7	7.93	10	M3 X 0.5	23	34	71	5,746	10
* CW-M5	CG-M5	5	8	5.75	27	16.00	11	9	11.10	14	M5 X 0.8	22	30	64	8,247	18
	CW-M6	CG-M6	6	9	6.25	30	19.00	13	12.70	14	M6 X 1.0	23	31	65	11,895	25
	CW-M8	CG-M8	8	12	8.00	36	22.25	16	15.88	17	M8 X 1.25	28	38	59	15,190	40
	CW-M10	CG-M10	10	14	9.50	43	27.00	19	19.05	21	M10 X 1.5	26	35	57	22,750	80
	CW-M12	CG-M12	12	16	10.75	50	30.00	22	22.23	24	M12 X 1.75	27	34	57	25,819	95
* CW-M14	CG-M14	14	19	12.25	57	34.75	25	22	25.40	27	M14 X 2.0	30	39	55	35,214	160
	CW-M16	CG-M16	16	21	12.75	64	38.00	27	28.58	33	M16 X 2.0	33	42	59	37,391	215
* CW-M18	CG-M18	18	23	14.75	71	42.00	31	27	31.75	36	M18 X 1.5	30	37	56	47,903	300
	CW-M20	CG-M20	20	25	16.25	77	46.00	34	34.93	40	M20 X 1.5	29	36	55	57,101	350

timkenaurorabearing.com • Fax 630-859-0971

METRIC