

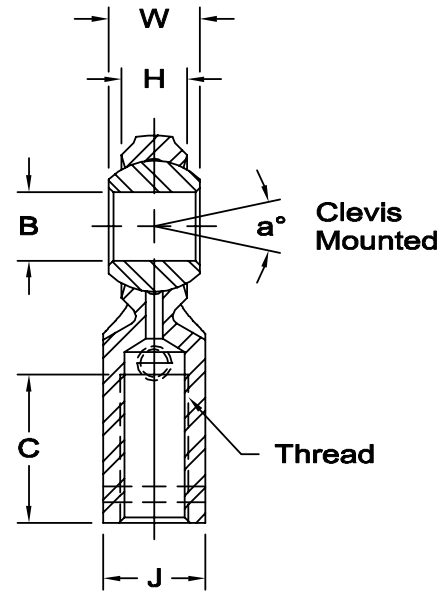

# CW & CG SERIES FEMALE ROD ENDS

General Purpose - Economy

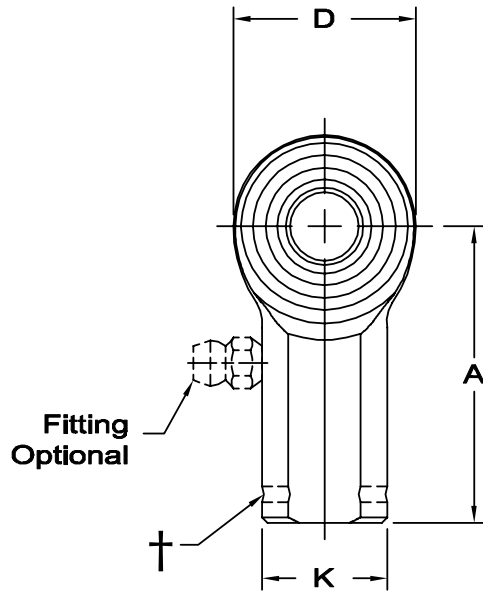

**Body** - Low carbon steel, protective coated for corrosion resistance.

**Ball** - Alloy steel, heat treated, hard chrome plated.

**Notes** - All sizes available with studs upon request.

†Left hand units have identification groove near end of shank.

\* Grease fittings not available on these sizes. Units are supplied without grease fittings. When a grease fitting is required, specify by adding suffix as designated.

Z Zerk type fitting  
F Flush type fitting

Ex: CW-6Z  
Ex: CW-6F

ROD END NO.		DIMENSIONS IN INCHES										a° Misalign. Angle	Ultimate Radial Static Load Capacity Lbs.	Approx. Brg. Wt. Lbs.
Right Hand	Left Hand†	B +.0025 -.0005	W ± .005	H Ref.	A ± .015	D Ref.	K ± .010	J ± .010	Ball Dia. Ref.	C + .062 - .031	Thread UNF-2B			
CW-3*	CG-3*	.1900	.312	.234	1.062	.625	.406	.312	.437	.500	10-32	20	2,079	.04
CW-4	CG-4	.2500	.375	.250	1.312	.750	.469	.375	.500	.687	1/4-28	27	3,208	.05
CW-5	CG-5	.3125	.437	.312	1.375	.875	.500	.437	.625	.687	5/16-24	22	3,824	.08
CW-6	CG-6	.3750	.500	.359	1.625	1.000	.687	.562	.719	.812	3/8-24	22	5,087	.13
CW-7	CG-7	.4375	.562	.406	1.812	1.125	.750	.625	.812	.937	7/16-20	21	6,385	.18
CW-8	CG-8	.5000	.625	.453	2.125	1.312	.875	.750	.937	1.062	1/2-20	20	9,096	.29
CW-10	CG-10	.6250	.750	.484	2.500	1.500	1.000	.875	1.125	1.375	5/8-18	26	9,713	.43
CW-12	CG-12	.7500	.875	.593	2.875	1.750	1.125	1.000	1.312	1.562	3/4-16	24	14,207	.65

ROD END NO.		DIMENSIONS IN MILLIMETERS										a° Misalign. Angle	Ultimate Radial Static Load Capacity Newtons	Approx. Brg. Wt. Grams
Right Hand	Left Hand†	B + .064 - .013	W ± .13	H Ref.	A ± .38	D Ref.	K ± .25	J ± .25	Ball Dia. Ref.	C + 1.57 - .79	Thread UNF-2B			
CW-3*	CG-3*	4.826	7.92	5.94	26.97	15.88	10.31	7.92	11.10	12.70	10-32	20	9,247	18
CW-4	CG-4	6.350	9.53	6.35	33.32	19.05	11.91	9.53	12.70	17.45	1/4-28	27	14,269	23
CW-5	CG-5	7.938	11.10	7.92	34.93	22.23	12.70	11.10	15.88	17.45	5/16-24	22	17,009	36
CW-6	CG-6	9.525	12.70	9.12	41.28	25.40	17.45	14.27	18.26	20.62	3/8-24	22	22,627	59
CW-7	CG-7	11.113	14.27	10.31	46.02	28.58	19.05	15.88	20.62	23.80	7/16-20	21	28,400	82
CW-8	CG-8	12.700	15.88	11.50	53.98	33.32	22.23	19.05	23.80	26.97	1/2-20	20	40,459	132
CW-10	CG-10	15.875	19.05	12.29	63.50	38.10	25.40	22.23	28.58	34.93	5/8-18	26	43,203	195
CW-12	CG-12	19.050	22.23	15.06	73.03	44.45	28.58	25.40	33.32	39.67	3/4-16	24	63,193	295

timkenaurorabearing.com • Fax 630-859-0971