

Flange Units - Standard 2 Bolt FHFT200-G Series Eccentric Locking Collar

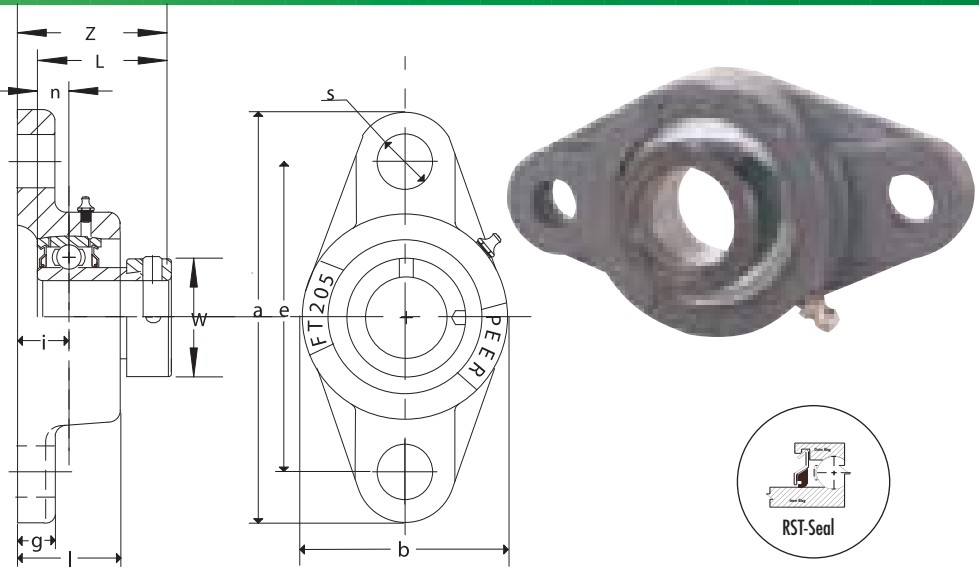

- Standard duty, high-grade cast iron
- Solid base housing design for added strength
- Narrow inner ring bearing
- Relubricatable unit (shown)
- Non-relubricatable unit available (omit "G" from unit part number)
- Standard seal: RST tight riding, full cover, metal shroud seals

Optional seals: See page 85



Dimensions ⁱⁿ_{mm}

Unit No.	Shaft Diam.	a	e	i	g	l	s	b	Z	L	n	W	Bolt Size In.	Bearing No.	Housing No.
FHFT201D -8G FHFT201D -12mmG FHFT202D -9G FHFT202D -10G FHFT202D -15mmG FHFT203D -11G FHFT203D -17mmG	1/2 12mm 9/16 5/8 15mm 11/16 17mm	3 29/32 99.2	3 76.2	.515 13.10	25/64 10.0	55/64 21.8	27/64 11.0	2 1/8 54.0	1.39 35.2	1.126 28.60	0.256 6.50	1.13 28.60	3/8	FH201 -8G FH201 -12mmG FH202 -9G FH202 -10G FH202 -15mmG FH203 -11G FH203 -17mmG	FTJ-203SD-H
FHFT204 -12G FHFT204 -20mmG	3/4 20mm	4 7/16 113.0	3 17/32 89.7	.591 15.00	7/16 11.1	15/16 24.0	27/64 11.0	2 3/8 60.3	1.52 38.5	1.220 31.00	0.295 7.50	1.26 32.00	3/8	FH204 -12G FH204 -20mmG	FT-204-H
FHFT205 -13G FHFT205 -14G FHFT205 -15G FHFT205 -16G FHFT205 -25mmG	13/16 7/8 15/16 1 25mm	5 1/8 130.2	3 57/64 98.8	.630 16.00	1/2 12.7	1 1/64 26.0	17/32 13.5	2 11/16 68.3	1.56 39.5	1.220 31.00	0.295 7.50	1.50 38.10	7/16	FH205 -13G FH205 -14G FH205 -15G FH205 -16G FH205 -25mmG	FT-205-H
FHFT206 -17G FHFT206 -18G FHFT206 -19G FHFT206 -20G FHFT206 -30mmG	1 1/16 1 1/8 1 3/16 1 1/4(s) 30mm	5 13/16 147.6	4 19/32 116.7	.709 18.00	1/2 12.7	1 5/32 29.0	17/32 13.5	3 5/32 80.2	1.76 44.7	1.406 35.70	0.354 9.00	1.75 44.50	7/16	FH206 -17G FH206 -18G FH206 -19G FH206 -20G FH206 -30mmG	FT-206-H
FHFT207 -20G FHFT207 -21G FHFT207 -22G FHFT207 -23G FHFT207 -35mmG	1 1/4 1 5/16 1 3/8 1 7/16 35mm	6 11/32 161.1	5 1/8 130.2	.748 19.00	9/16 14.3	1 3/16 30.0	37/64 15.0	3 17/32 89.7	1.91 48.4	1.531 38.90	0.374 9.50	2.19 55.60	1/2	FH207 -20G FH207 -21G FH207 -22G FH207 -23G FH207 -35mmG	FT-207-H
FHFT208 -24G FHFT208 -25G FHFT208 -40mmG	1 1/2 1 9/16 40mm	6 7/8 174.6	5 21/32 143.7	.828 21.00	9/16 14.3	1 13/32 34.0	37/64 15.0	3 15/16 100.0	2.11 53.7	1.720 43.70	0.433 11.00	2.38 60.40	1/2	FH208 -24G FH208 -25G FH208 -40mmG	FT-208-H
FHFT209 -26G FHFT209 -27G FHFT209 -28G FHFT209 -45mmG	1 5/8 1 11/16 1 3/4 45mm	7 13/32 188.1	5 27/32 148.4	.866 22.00	19/32 15.1	1 3/8 35.0	21/32 17.0	4 1/4 108.0	2.15 54.7	1.720 43.70	0.433 11.00	2.50 63.50	9/16	FH209 -26G FH209 -27G FH209 -28G FH209 -45mmG	FT-209-H
FHFT210 -29G FHFT210 -30G FHFT210 -31G FHFT210 -32G FHFT210 -50mmG	1 13/16 1 7/8 1 15/16 2(s) 50mm	7 3/4 196.9	6 3/16 157.2	.866 22.00	19/32 15.1	1 17/32 39.0	21/32 17.0	4 17/32 115.1	2.15 54.7	1.720 43.70	0.433 11.00	2.75 69.90	9/16	FH210 -29G FH210 -30G FH210 -31G FH210 -32G FH210 -50mmG	FT-210-H
FHFT211 -32G FHFT211 -33G FHFT211 -34G FHFT211 -35G FHFT211 -55mmG	2 2 1/16 2 1/8 2 3/16 55mm	8 13/16 223.8	7 1/4 184.2	1.000 25.40	23/32 18.3	1 5/8 41.4	45/64 18.0	5 1/8 130.2	2.41 61.3	1.906 48.40	0.492 12.50	3.00 76.20	5/8	FH211 -32G FH211 -33G FH211 -34G FH211 -35G FH211 -55mmG	FT-211-H
FHFT212 -36G FHFT212 -37G FHFT212 -38G FHFT212 -39G FHFT212 -60mmG	2 1/4 2 5/16 2 3/8 2 7/16 2 7/16	9 27/32 250.0	7 15/16 201.6	1.142 29.00	23/32 18.3	1 25/32 45.0	55/64 22.0	5 1/2 139.7	2.55 64.8	1.941 49.30	0.532 13.50	3.31 84.20	3/4	FH212 -36G FH212 -37G FH212 -38G FH212 -39G FH212 -60mmG	FT-212-H

Standard Mounted Units

1. Bolt hole diameter ('s' dimension) can be drilled to your specifications
2. Overall length ('a' dimension) can be made to your specifications