

GUIDE FSHZ FSXZ

LUBRICATION WHEEL LUBZ..

5.1

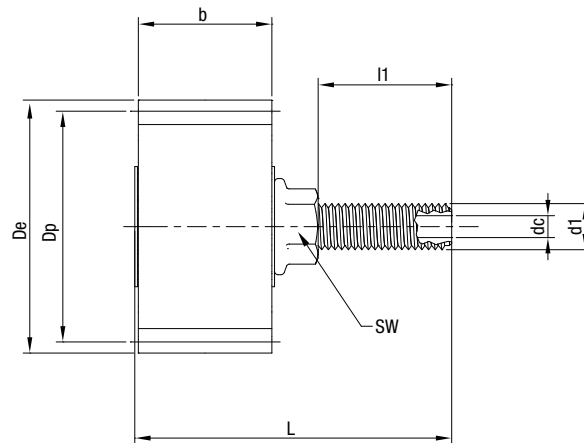

Type		Z	m	De	Dp	b	dc	d1	L	l1	SW	Weight (Kg)
LUBZ15D	Material: open cell poliuretane foam	24	m 1.5	39	36	15	M6	M10	60.2	34	17	0.07
LUBZ20D		17	m 2	38	34	20	M6	M10	61	30	17	0.08
LUBZ30D		17	m 3	57	51	30	M6	M10	71	30	17	0.11