

Combined bearings with incorporated thrust plate RAXPZ 400 – RAXZ 500

Machine-tool
quality combined
bearings
RAXNPZ 400,
RAXNZ 500
series

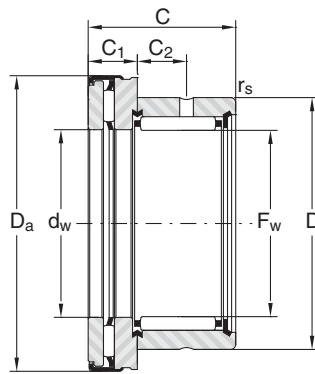

RAXPZ400 - RAXNPZ 400

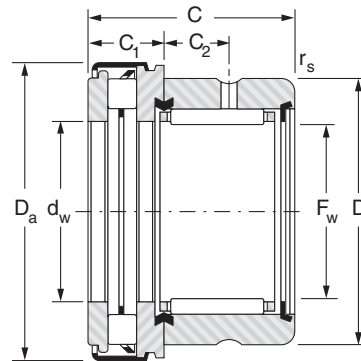

RAXZ 500 - RAXNZ 500

Shaft ∅ mm	Designations		F _w mm	D mm	C mm	d _a mm	D _a mm	C ₁ mm	C ₂ mm	r _{s min} mm
	RAXPZ 400 series	RAXZ 500 series								
10	RAXPZ 410		10	19	21	10	22.4	7	6	0.35
		RAXZ 510	10	19	21.5	10	22.4	7.5	6	0.35
12	RAXPZ 412		12	21	21	12	26.4	7	6	0.35
		RAXZ 512	12	21	22	12	26.4	8	6	0.35
15	RAXPZ 415		15	24	21	15	28.4	7	6	0.35
		RAXZ 515	15	24	22	15	28.4	8	6	0.35
17	RAXPZ 417		17	26	23	17	30.4	7	8	0.65
		RAXZ 517	17	26	24	17	30.4	8	8	0.65
20	RAXPZ 420		20	30	27	20	35.4	9	9	0.85
		RAXZ 520	20	30	29	20	35.4	11	9	0.85
25	RAXPZ 425		25	37	27	25	43	9	9	0.85
		RAXZ 525	25	37	29	25	43	11	9	0.85
30	RAXPZ 430		30	42	27	30	48	9	9	0.85
		RAXZ 530	30	42	29	30	48	11	9	0.85
35	RAXPZ 435		35	71	27	35	54	9	9	0.85
		RAXZ 535	35	47	30	35	54	12	9	0.85
40	RAXPZ 440		40	52	27	40	61	9	9	0.85
		RAXZ 540	40	52	31	40	61	13	9	0.85
45	RAXPZ 445		45	58	27	45	66	9	9	0.85
		RAXZ 545	45	58	31	45	66	13	9	0.85
50	RAXPZ 450		50	62	30	50	71	9	11	1.3
		RAXZ 550	50	62	34	50	71	13	11	1.3
60	RAXPZ 460		60	72	32	60	86	11	11	1.3
		RAXZ 560	60	72	36	60	86	15	11	1.3
70	RAXPZ 470		70	85	32	70	96	11	11	1.3
		RAXZ 570	70	85	36	70	96	15	11	1.3

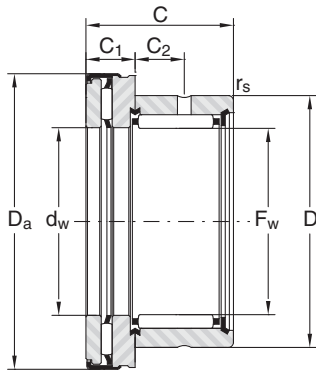

RAXPZ400 - RAXNPZ 400

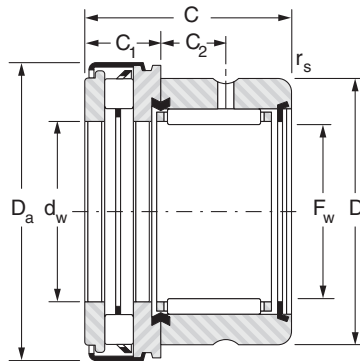

RAXZ 500 - RAXNZ 500

Load Ratings kN				Speed rating min ⁻¹	Weight kg	Shaft ∅ mm
Radial		Axial				
Dyn. C	Stat. Co	Dyn. C	Stat. Co			
5.9	7.2	5	10.9	15500	0.029	10
5.9	7.2	8.2	17.9	15500	0.031	
6.8	9	7.1	18.5	13000	0.038	12
6.8	9	12.7	29.5	13000	0.039	
9.66	12.6	7.6	20.8	11500	0.040	15
9.66	12.6	14	34	11500	0.044	
11.8	16.3	8.1	23	10500	0.048	17
11.8	16.3	15	39	10500	0.053	
14.8	23.7	11.8	39	9000	0.079	20
14.8	23.7	22	54	9000	0.086	
15.1	26.2	13.3	49	7500	0.118	25
15.1	26.2	25.5	70	7500	0.131	
20.2	34.6	14.5	57	6.500	0.133	30
20.2	34.6	26.5	77	6.500	0.147	
22.1	40.8	18.9	84	5.500	0.157	35
22.1	40.8	33.8	94	5.500	0.181	
23.8	47	20.4	96	5.000	0.184	40
23.8	47	46	129	5.000	0.218	
24.9	51.8	21.8	109	4.500	0.216	45
24.9	51.8	49	143	4.500	0.255	
30.2	68.5	22.5	118	4.000	0.245	50
30.2	68.5	51	157	4.000	0.287	
31.9	78.1	31.5	193	3.500	0.365	60
31.9	78.1	71	255	3.500	0.423	
36.1	84.7	34.5	223	3.000	0.479	70
36.1	84.7	77	295	3.000	0.545	