

HOCHLEISTUNGS-GELENKKÖPFE
Mit fixiertem Gleitlager, Maßreihe K, Innengewinde, Anschlussmaße nach DIN ISO 12240-4 und DIN ISO 8139

HEAVY-DUTY ROD ENDS
 With pressed spherical plain bearing, series K, female thread, according to DIN ISO 12240-4 and thread according to DIN ISO 8139

→ **Sonderanfertigungen auf Anfrage**
 → Custom made products on request

Gehäuse:
 Geschmiedeter Einsatzstahl vergütet, Oberfläche galvanisch verzinkt, Cr VI-frei
Außenring:
 Lagermessing mit Schmiernut und -bohrungen
Gelenkkugel:
 Wälzlagerstahl gehärtet, geschliffen, poliert, Lauffläche hartverchromt
Wartung:
 Wartungspflichtig - Im Anlieferzustand geölt - Erstschiemung durch Anwender
Schmiernippel:
 Trichterschmiernippel DIN 3405 D1/A, ab Größe 6 Schmiernippel an Pos. 1, weitere Schmiernippel siehe Seite 063
Toleranzen:
 Seite 050 - 057

Housing:
 Forged steel, tempered, surface galvanized, free of Cr VI
Outer ring:
 Bearing brass, oil groove and drill holes
Joint ball:
 Ball bearing steel, hardened, ground, polished and hard chromium plated
Maintenance:
 Maintenance required, oiled on delivery, initial lubrication by the user
Grease nipple:
 DIN 3405 D1/A, from size 6 grease nipple on pos. 1, further grease nipple see on page 063
Tolerances:
 Page 050 - 057

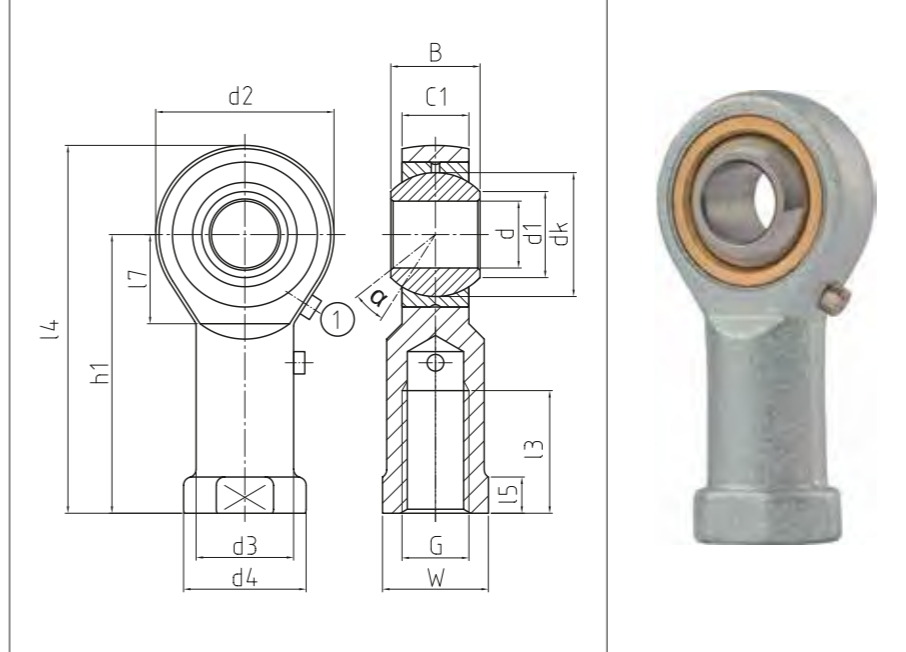

BEFN

Hochleistungs-Gelenkköpfe
 Heavy-duty rod ends

CLASSIC Line X

Bestellnummer Order number			Abmessungen Measurements [mm]																	Kippwinkel Tilt angle	Gewicht Weight	Tragzahlen Basic load rating		Radiale Lagerluft Radial clearance	
Typ Type	Rechtsgewinde Right hand thread	Linksgewinde Left hand thread	d	G	B	C1	h1	d1	d2	d3	d4		dk	l3	l4	l5	l7	W	α [°]	[kg]	dyn C [kN]	stat Co [kN]	CN [µm]	d	
BEFN 05 - 20	-501	-502	5	M 5	8	6	27	7,7	18	9	11		11,06	10	36	4	10	9	13	0,016	2,4	6	20 - 60	5	
BEFN 05 - 21	-501	-502	5	M 4	8	6	27	7,7	18	9	11		11,06	10	36	4	10	9	13	0,016	2,4	6	20 - 60	5	
BEFN 06 - 20	-501	-502	6	M 6	9	6,75	30	8,9	20	10	13		12,65	12	40	5	10	11	13	0,022	3,0	7,5	20 - 60	6	
BEFN 08 - 20	-501	-502	8	M 8	12	9	36	10,3	24	12,5	16		15,82	16	48	5	12	14	13	0,047	4,8	11,9	20 - 60	8	
BEFN 10 - 20	-501	-502	10	M 10	14	10,5	43	12,9	28	15	19		19	20	57	6,5	15	17	13	0,077	5,8	14,5	40 - 90	10	
BEFN 10 - 21	-501	-502	10	M 10 x 1,25	14	10,5	43	12,9	28	15	19		19	20	57	6,5	15	17	13	0,077	5,8	14,5	40 - 90	10	
BEFN 12 - 20	-501	-502	12	M 12	16	12	50	15,4	32	17,5	22		22,17	22	66	6,5	16	19	13	0,1	7	17,5	40 - 90	12	
BEFN 12 - 21	-501	-502	12	M 12 x 1,25	16	12	50	15,4	32	17,5	22		22,17	22	66	6,5	16	19	13	0,1	7	17,5	40 - 90	12	
BEFN 14 - 20	-501	-502	14	M 14	19	13,5	57	16,8	36	20	25		25,35	25	75	8	20	22	15	0,16	10	25,1	40 - 90	14	
BEFN 16 - 20	-501	-502	16	M 16	21	15	64	19,3	42	22	27		28,52	28	85	8	22	22	15	0,22	11,4	28,5	50 - 110	16	
BEFN 16 - 21	-501	-502	16	M 16 x 1,5	21	15	64	19,3	42	22	27		28,52	28	85	8	22	22	15	0,22	11,4	28,5	50 - 110	16	
BEFN 18 - 20	-501	-502	18	M 18 x 1,5	23	16,5	71	21,8	46	25	31		31,7	32	94	10	24	27	15	0,32	17,6	44	50 - 110	18	
BEFN 20 - 20	-501	-502	20	M 20 x 1,5	25	18	77	24,3	50	27,5	34		34,87	33	102	10	26	30	15	0,42	20	50	50 - 110	20	
BEFN 22 - 20	-501	-502	22	M 22 x 1,5	28	20	84	25,8	54	30	38		38,05	37	111	12	26	32	15	0,54	22,8	59	60 - 120	22	
BEFN 25 - 20	-501	-502	25	M 24 x 2	31	22	94	29,5	60	33,5	42		42,8	42	124	12	30	36	15	0,73	28	70	60 - 120	25	
BEFN 30 - 20	-501	-502	30	M 30 x 2	37	25	110	34,8	70	40	50		50,75	51	145	15	35	41	15	1,1	36	90	60 - 120	30	
BEFN 30 - 21	-501	-502	30	M 27 x 2	37	25	110	34,8	70	40	50		50,75	51	145	15	35	41	15	1,1	36	90	60 - 120	30	

HOCHLEISTUNGS-GELENKKÖPFE
In rostfreier Edelstahlaus-
führung, mit fixiertem Gleit-
lager, Maßreihe K, Innengewinde,
Anschlussmaße nach DIN ISO
12240-4 und DIN ISO 8139

HEAVY-DUTY ROD ENDS
 In stainless steel, with pressed
 spherical plain bearing, series K,
 female thread, according to DIN
 ISO 12240-4 and thread according
 to DIN ISO 8139

- Sonderanfertigungen auf Anfrage
- Custom made products on request

Gehäuse:
 Geschmiedeter, rostfreier Edelstahl, Ober-
 fläche elektropoliert
Außenring:
 Lagermessing mit Schmiernut und
 -bohrungen
Gelenkkugel:
 Rostfreier Edelstahl gehärtet, geschliffen,
 poliert
Wartung:
 Wartungspflichtig - Im Anlieferzustand geölt -
 Erstschnierung durch Anwender
Schmiernippel:
 Trichterschmiernippel DIN 3405 D1/A, ab
 Größe 6 Schmiernippel an Pos. 1, weitere
 Schmiernippel siehe Seite 063
Toleranzen:
 Seite 050 - 057

Housing:
 Stainless steel, forged, surface electro-
 polished
Outer ring:
 Bearing brass, oil groove and drill holes
Joint ball:
 Stainless steel, hardened, ground, polished
Maintenance:
 Maintenance required, oiled on delivery, initial
 lubrication by the user
Grease nipple:
 DIN 3405 D1/A, from size 6 grease nipple on
 pos. 1, further grease nipple see on page 063
Tolerances:
 Page 050 - 057

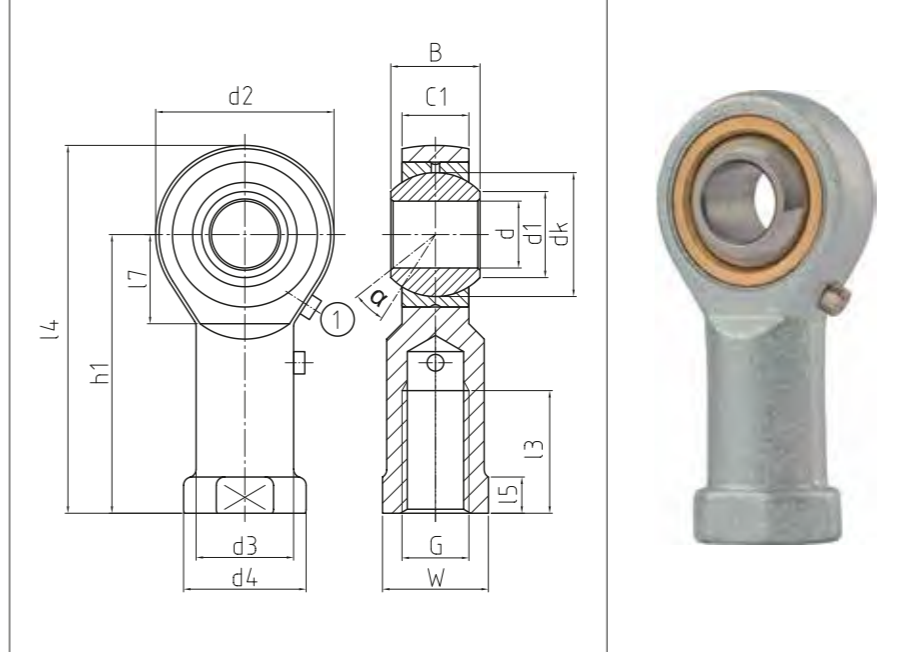

BEFN^{NIRO}

Hochleistungs-Gelenkköpfe
 Heavy-duty rod ends

CLASSIC Line X

Bestellnummer Order number			Abmessungen Measurements [mm]														Kippwinkel Tilt angle	Gewicht Weight	Tragzahlen Basic load rating		Radiale Lagerluft Radial clearance			
Typ Type	Rechtsgewinde Right hand thread	Linksgewinde Left hand thread	d	G	B	C1	h1	d1	d2	d3	d4		dk	l3	l4	l5	l7	W	α [°]	[kg]	dyn C [kN]	stat Co [kN]	CN [µm]	d
BEFN 05 - 80	-501	-502	5	M 5	8	6	27	7,7	18	9	11		11,06	10	36	4	10	9	13	0,016	2	4	20 - 60	5
BEFN 05 - 81	-501	-502	5	M 4	8	6	27	7,7	18	9	11		11,06	10	36	4	10	9	13	0,016	2	4	20 - 60	5
BEFN 06 - 80	-501	-502	6	M 6	9	6,75	30	8,9	20	10	13		12,65	12	40	5	10	11	13	0,022	2,5	5	20 - 60	6
BEFN 08 - 80	-501	-502	8	M 8	12	9	36	10,3	24	12,5	16		15,82	16	48	5	12	14	13	0,047	3,6	7,9	20 - 60	8
BEFN 10 - 80	-501	-502	10	M 10	14	10,5	43	12,9	28	15	19		19	20	57	6,5	15	17	13	0,077	4,7	9,7	40 - 90	10
BEFN 10 - 81	-501	-502	10	M 10 x 1,25	14	10,5	43	12,9	28	15	19		19	20	57	6,5	15	17	13	0,077	4,7	9,7	40 - 90	10
BEFN 12 - 80	-501	-502	12	M 12	16	12	50	15,4	32	17,5	22		22,17	22	66	6,5	16	19	13	0,1	6,5	11,7	40 - 90	12
BEFN 12 - 81	-501	-502	12	M 12 x 1,25	16	12	50	15,4	32	17,5	22		22,17	22	66	6,5	16	19	13	0,1	6,5	11,7	40 - 90	12
BEFN 14 - 80	-501	-502	14	M 14	19	13,5	57	16,8	36	20	25		25,35	25	75	8	20	22	15	0,16	8,5	16,7	40 - 90	14
BEFN 16 - 80	-501	-502	16	M 16	21	15	64	19,3	42	22	27		28,52	28	85	8	22	22	15	0,22	10,7	19	50 - 110	16
BEFN 16 - 81	-501	-502	16	M 16 x 1,5	21	15	64	19,3	42	22	27		28,52	28	85	8	22	22	15	0,22	10,7	19	50 - 110	16
BEFN 18 - 80	-501	-502	18	M 18 x 1,5	23	16,5	71	21,8	46	25	31		31,7	32	94	10	24	27	15	0,32	15,8	29,3	50 - 110	18
BEFN 20 - 80	-501	-502	20	M 20 x 1,5	25	18	77	24,3	50	27,5	34		34,87	33	102	10	26	30	15	0,42	18,5	33,4	50 - 110	20
BEFN 22 - 80	-501	-502	22	M 22 x 1,5	28	20	84	25,8	54	30	38		38,05	37	111	12	26	32	15	0,54	20,2	38	60 - 120	22
BEFN 25 - 80	-501	-502	25	M 24 x 2	31	22	94	29,5	60	33,5	42		42,8	42	124	12	30	36	15	0,73	26,5	46,7	60 - 120	25
BEFN 30 - 80	-501	-502	30	M 30 x 2	37	25	110	34,8	70	40	50		50,75	51	145	15	35	41	15	1,1	32	60	60 - 120	30
BEFN 30 - 81	-501	-502	30	M 27 x 2	37	25	110	34,8	70	40	50		50,75	51	145	15	35	41	15	1,1	32	60	60 - 120	30