

SEALED (MOLDED) 4-POINT CONTACT, X-TYPE THIN SECTION BALL BEARINGS

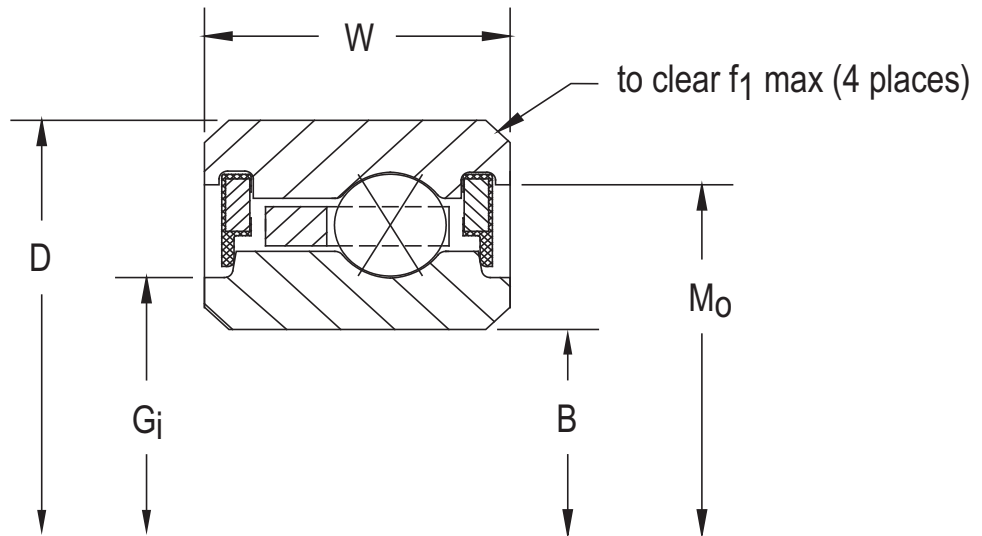

PART NUMBER*	NOMINAL DIMENSIONS												
	B Bore		D Outside Diameter		W Width		G _i Recess Diameter		M _o Groove Diameter		f ₁ Housing Fillet		Ball Diameter
	in.	mm	in.	mm	in.	mm	in.	mm	in.	mm	in.	mm	in.
JHA10XL0*RBC	1.0000	25.400	1.3750	34.925	0.250	6.350	1.093	27.762	1.260	32.004	0.015	0.38	3/32
JHA15XL0*RBC	1.5000	38.100	1.8750	47.625	0.250	6.350	1.593	40.462	1.760	44.704	0.015	0.38	3/32
JHA17XL0*RBC	1.7500	44.450	2.1250	53.975	0.250	6.350	1.843	46.812	2.010	51.054	0.015	0.38	3/32

*The alphanumeric identification system is used under license.

- 52100 Steel
- Large Diameter
- Light Weight
- Small Cross Section
- Snap-Over Ball Separator
- Sealed



JHA-SERIES

	Ball Quantity	Approx. Weight		LOAD RATINGS										PART NUMBER*		
				Radial				Thrust				Moment				
				Static		Dynamic		Static		Dynamic		Static	Dynamic		Static	Dynamic
lbs.	kg	lbf	N	lbf	N	lbf	N	lbf	N	lbf - in	Nm	lbf - in	Nm			
	22	0.035	0.016	290	1,290	270	1,200	730	3,250	680	3,020	170	20	160	20	JHA10XL0*RBC
	30	0.052	0.024	400	1,780	301	1,380	1,000	4,450	770	3,430	340	40	260	30	JHA15XL0*RBC
	33	0.060	0.027	460	2,050	322	1,430	1,140	5,070	805	3,580	555	63	405	46	JHA17XL0*RBC

Refer to the Engineering section for load and speed limitations.